



cooling & heating



# OPERATING MANUAL

TITLE

CoolMaster L-Cube Series

REVISION

F

**INDEX**

**DISCLAIMER** ..... 3

**1 SAFETY INSTRUCTIONS AND WARNINGS**..... 4

    1.1 CORRECT APPLICATIONS ..... 5

    1.2 INCORRECT APPLICATIONS..... 5

**2 GENERAL DESCRIPTION** ..... 6

    2.1 COOLMASTER K, N, NF, NO AND NOF ..... 6

    2.2 COOLMASTER L, O AND OF..... 8

    2.3 IDENTIFICATION ..... 10

**3 TRANSPORT AND STORAGE** ..... 11

    3.1 DRAINING WATER FROM COOLMASTER K AND L ..... 11

    3.2 DRAINING WATER/ GLYCOL MIXTURE FROM COOLMASTER N, NF, NO, NOF, O AND OF ..... 11

    3.3 PACKING, TRANSPORT AND STORAGE INSTRUCTIONS ..... 11

**4 COMMISSIONING**..... 12

    4.1 INSTALLATION COOLMASTER K, N, NF, NO AND NOF ..... 12

    4.2 INSTALLATION COOLMASTER L, O AND OF ..... 12

    4.3 CONNECTING COOLING WATER PIPES\* ..... 16

    4.4 CONNECTING DRAINAGE/OVERFLOW PIPE (C+E) ..... 18

    4.5 CONNECTING REFRIGERANT RELIEF (V) IF APPLICABLE ..... 18

    4.6 CONNECTING POWER SUPPLY ..... 19

    4.7 CONNECTING EXTERNAL CONTACTS ..... 19

    4.8 WATER QUALITY ..... 20

    4.9 FILLING OF (EXTERNAL) PIPES AND SYSTEMS COOLMASTER K AND L ..... 21

    4.10 FILLING OF (EXTERNAL) PIPES AND SYSTEMS COOLMASTER N, NF, NO, NOF, O AND OF ..... 22

    4.11 FILLING OF THE SYSTEMS COOLMASTER K AND L ..... 25

    4.12 FILLING OF THE SYSTEMS COOLMASTER N, NF, NO, NOF, O AND OF ..... 26

    4.13 DEAERATING ..... 27

    4.14 SETTING THERMOSTAT (IF APPLICABLE)..... 28

    4.15 COMMISSIONING AFTER LONG STANDSTILL ..... 29

**5 ALARM SIGNALS (IF APPLICABLE)**..... 30

**6 FAULT ANALYSIS**..... 31

**7 MAINTENANCE AND CLEANING** ..... 32

    7.1 MINIMUM INSPECTION-INTERVAL SCHEME ..... 33

    7.2 CLEANING OF THE MACHINE ..... 35

**8 REMOVAL** ..... 36

**9 APPENDIX** ..... 37

    9.1 CONNECTION DIAGRAM FILLING THE SYSTEM ..... 38

    9.2 WATER TREATMENT ..... 39

    9.3 GUIDELINE FOR WATER QUALITY IN DTE INSTALLATIONS ..... 41

    9.4 MANUAL FOR LOCKED WATER PUMP AFTER A LONG PERIOD OF STAND STILL ..... 42

    9.5 USER MANUAL THERMOSTAT (IF APPLICABLE)\* ..... 44

    9.6 INSTRUCTIONS OF PARTLY COMPLETED MACHINERY (IF APPLICABLE) ..... 45

    9.7 DECLARATION OF CONFORMITY\* ..... 46

    9.8 GUARANTEE..... 48

    9.9 COMMENTS ..... 49

    9.10 TECHNICAL INFORMATION\* ..... 50

        ➤ **Machine drawing**..... 50

        ➤ **P&ID**..... 50

        ➤ **Spare parts list** ..... 50

        ➤ **Electrical diagram**..... 50

        ➤ **Safety data sheet refrigerant** ..... 50

        ➤ **Safety data sheet monoethylene glycol (MEG)** ..... 50

        ➤ **Other**..... 50

## Disclaimer

The manufacturer reserves the right to change parts at any time to change, without prior or immediate notice to the customer. The contents of this manual may also be changed without prior warning. This is an original manual, and is valid for the machine in its standard version. For information on adjustments, maintenance and repair insofar as this guide does not provide it, please contact the technical department of your supplier. This manual was drawn up with the greatest possible care, however the manufacturer cannot accept any liability for any errors in this book or any consequences thereof. Finally, this manual is a personal and confidential communication to the user. No part of this publication may be reproduced, copied, altered or transmitted in any form or in any manner whatsoever without written permission from Dutch Thermal Engineering B.V.

## 1 Safety instructions and warnings

**Always observe the following safety instructions and warnings!**



**WARNING!**

Warning of possible damage to the device, environment or user



**WARNING!**

Warning of electricity and / or current threat



**WARNING!**

Warning of possible entrapment hazard

This user's manual was written for types similar to DTE **CoolMaster K, N, NF, NO, NOF, L, O and OF**, type machines. Therefore certain topics may not apply to your machine. For the same reason, the images may differ slightly from how your machine actually looks. The machine drawing is sent separately as an attachment with the correct dimensions and connections.

For more information about the different types of **CoolMaster** machines, see chapter §1.1.



Compliance with the technical manual is a prerequisite for fault-free operation and the honouring of any warranty claims. Therefore please read the technical manual carefully before you start working with your device! The manual must therefore be kept near the machine. The **CoolMaster** is under pressure with a refrigerant, more information about this can be found in appendix §9.10.

## 1.1 Correct applications



**ATTENTION!** The *CoolMaster* must always have at least 3 metres free airflow above it. With an external condenser, this also applies to the condenser.



**ATTENTION!** In no way the machine can be stacked or overturned. This during transport and storing as well during repairs and commissioning. Even when the machine is not used it should be perpendicular at all times.



**ATTENTION!** Not following these instruction can cause big damage to the machine.

The *CoolMaster K, L, N, NF, O and OF* may only be kept inside a cool, well-ventilated, frost-free building!

The *CoolMaster K* is only suitable for tap water of drinking quality.

The *CoolMaster L* with external condenser is only suitable for tap water of drinking quality.

The *CoolMaster NO* is applicable for outdoor installation with ambient temperature until - 15°C by preference under shelter.

The *CoolMaster NOF* is applicable for outdoor installation with ambient temperature until - 30°C by preference under shelter.

The *CoolMaster O and OF* with external condenser is only suitable for water/glycol.

The *CoolMaster N, NF, NO, NOF, O and OF* is only suitable for tap water of drinking quality, mixing with appropriate antifreeze (glycol) in suitable mixing ratio.

Please consult the relevant P&ID for information on the minimum and maximum environmental temperature, the right water-glycol ratio and the recommended type of glycol.

## 1.2 Incorrect applications



**CAUTION!** Application is **prohibited**:

- In explosive atmospheres.
- In environments with hazardous oils, acids, gases, fumes, substances, radiation, etc.
- Corrosive environment.

## 2 General description

### 2.1 CoolMaster K, N, NF, NO and NOF

The **CoolMaster** is a complete plug and play water cooler with integrated water cooler tank, pump, condenser and controls. Is built for perfect cooling in closed industrial process water systems.

**CoolMaster** sample drawing range L1\*:

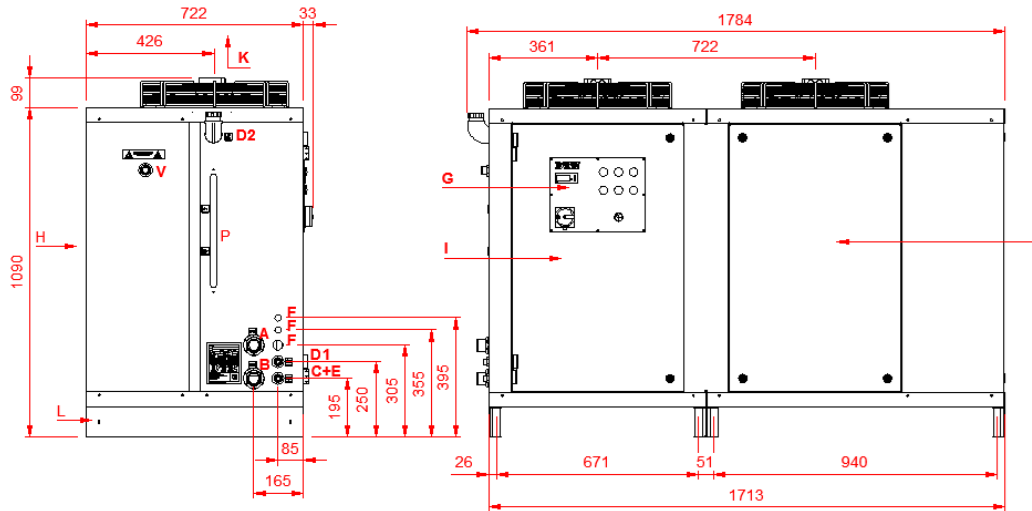











\*The machine drawing is sent separately as an attachment with the correct dimensions and connections!

**Overview of the most common connections on the machine:**



**NOTE! WHEN THE MACHINE IS RUNNING THE SERVICE PANELS SHOULD BE PLACED ON THE MACHINE AND CONTROL BOX DOORS ARE CLOSED!**

A	=		Cooling water inlet, see P&ID
B	=		Cooling water outlet, see P&ID
C	=		Drainage water tank, see P&ID
C+E	=		Drainage/overflow water tank, see P&ID
C+E	=	 WATER / GLYCOL	Drainage/overflow water tank, see P&ID (only present on machines, specified as <b>CoolMaster N, NF, NO, NOF, O and OF</b> )
D1	=		Filling water connection, see P&ID (not present on machines, specified as <b>CoolMaster N, NF, NO, NOF, O and OF</b> )
D2	=		Manual filling device, see P&ID
D2	=	 WATER / GLYCOL	Manual filling device, see P&ID (only present on machines, specified as <b>CoolMaster N, NF, NO, NOF, O and OF</b> )
E	=		Overflow water tank, see P&ID
F	=		Bushing coupling electrical supply cable
G	=		Control panel
H	=		Incoming condenser air
I	=		Service panel / control box door
K	=		Outgoing condenser air
L	=		Legs, U-Profile
P / S	=		Sight glass
			Maximum water/glycol level
			Minimum water/glycol level
V	=		Refrigerant relief (if applicable), see P&ID

## 2.2 CoolMaster L, O and OF

The **CoolMaster** is a complete plug and play water cooler with integrated water cooler tank, pump, external condenser and controls. Is built for perfect cooling in closed industrial process water systems.

**CoolMaster** sample drawing range L1\*:

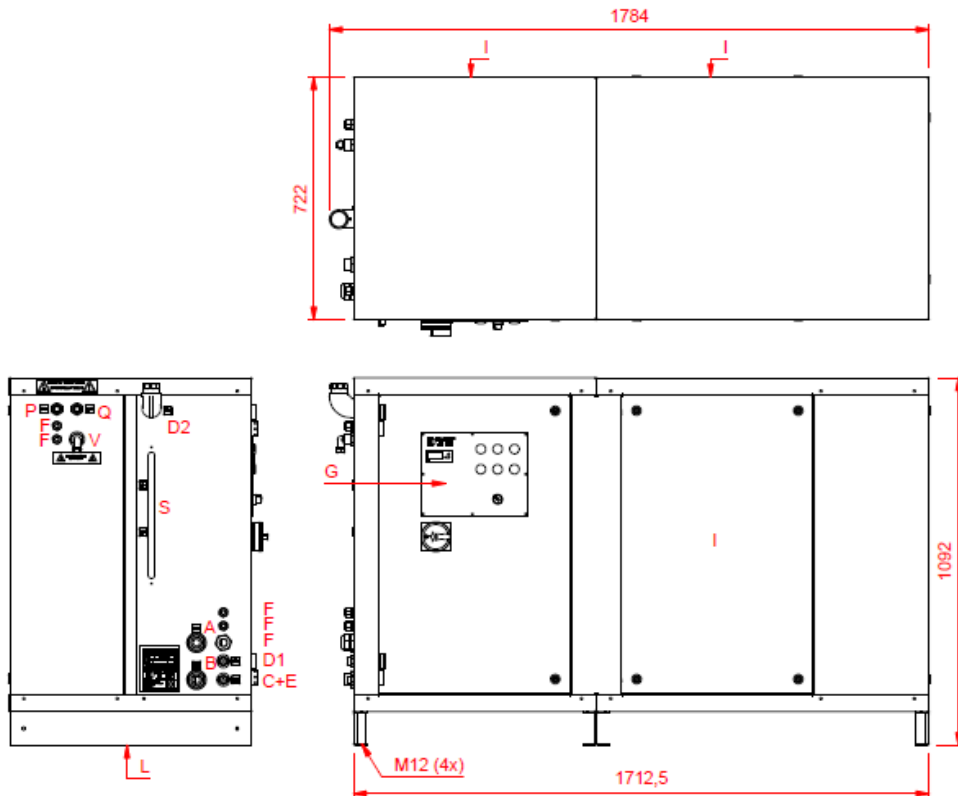

**External condenser** sample drawing range L1\*:

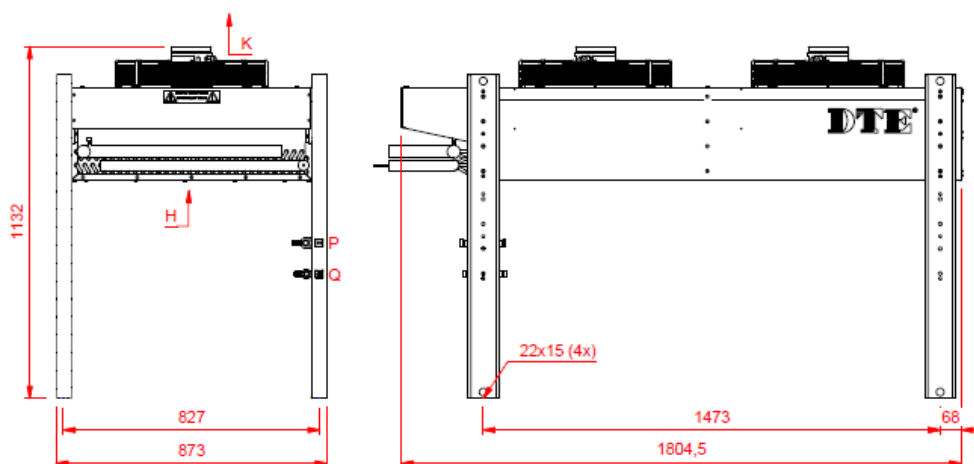















\*The machine drawing is sent separately as an attachment with the correct dimensions and connections!



**Overview of the most common connections on the machine:**



**NOTE! WHEN THE MACHINE IS RUNNING THE SERVICE PANELS SHOULD BE PLACED ON THE MACHINE AND CONTROL BOX DOORS ARE CLOSED!**

A	=		Cooling water inlet, see P&ID
B	=		Cooling water outlet, see P&ID
C	=		Drainage water tank, see P&ID
C+E	=		Drainage/overflow cooling section, see P&ID
C+E	=	 WATER / GLYCOL	Drainage/overflow water tank, see P&ID (only present on machines, specified as <b>CoolMaster N, NF, NO, NOF, O and OF</b> )
D1	=		Filling water connection, see P&ID (not present on machines, specified as <b>CoolMaster N, NF, NO, NOF, O and OF</b> )
D2/D3	=		Manual filling device, see P&ID
D2/D3	=	 WATER / GLYCOL	Manual filling device, see P&ID (only present on machines, specified as <b>CoolMaster N, NF, NO, NOF, O and OF</b> )
E	=		Overflow water tank, see P&ID
F	=		Bushing coupling electrical supply cable
G	=		Control panel
H	=		Incoming condenser air
I	=		Service panel / control box door
K	=		Outgoing condenser air
L	=		Legs, U-Profile
P	=		Hotgas pipe, see P&ID
Q	=		Liquid pipe, see P&ID
S	=		Sight glass
			Maximum water/glycol level
			Minimum water/glycol level
V	=		Refrigerant relief (if applicable), see P&ID
Z1	=		De-aeration water tank (if applicable), see P&ID

### 2.3 Identification

#### Standard Type plate:



The identification plate is located on the left side from the machine. (Figure 2.1)

- A = Machine number/ serial number
- B = Machine type
- C = Voltage
- D = Maximum current
- E = Number of phases
- F = Frequency in Hz.
- G = Refrigerant type
- H = Refrigerant mass
- I = Maximum ambient temperature
- J = CO2 equivalent
- K = GWP-values
- L = Thermostat Temperature range
- M = Maximum pressure
- N = Compressor lubrication
- O = Compressor oil volume
- P = Built
- Q = Weight
- R = Cooling capacity

Man. Nr.	A									
Type	B									
Volt.	C	V	I max.	D	A	Ph.	E	Hz.	F	
Refrigerant	G	H	kg	Max. Ambient	I		°C			
CO2 equivalent	J		ton	GWP-values	K					
Min./Max. Output	L		°C	Max. Pressure	M					Bar
Compressor Oil	N						O	cm <sup>3</sup>		
Built	P	MM - YYYY	Weight	Q			kg			
Capacity Unit	R						kW			



Dutch Thermal Engineering B.V.  
 Westerbroekstraat 18  
 7011 EX Gaanderen  
 Phone: +31(0)315-328311  
 E-mail: info@dte.eu  
 Internet: www.dte.eu

COUNTRY OF ORIGIN: The Netherlands

Figure 2.1

#### Type plate according 2014/68/EU PED-Directive and pressure equipment (Safety) Regulations 2016:

The identification plate is located on the left side from the machine. (Figure 2.2)

- A = Machine number/ serial number
- B = Machine type
- C = Voltage
- D = Maximum current
- E = Number of phases
- F = Frequency in Hz.
- G = Thermostat Temperature range
- H = Maximum ambient temperature
- I = Built
- J = Weight
- K = Cooling capacity
- L = Category
- M = Module
- N = Product low pressure
- O = Product high pressure
- P = Product temperature
- Q = GWP-values
- R = Refrigerant type
- S = Refrigerant mass
- T = CO2 equivalent

Man. No.	A									
Type	B									
Volt.	C	V	I max.	D	A	Ph.	E	Hz.	F	
Min./Max. Output	G		°C	Max. Ambient	H					°C
Built	I	MM - YYYY	Weight	J			kg			
Capacity Unit	K						kW			
Classification 2014/68/EU	L		M							
LP (PS)	N		BAR (g)	HP (PS)	O					BAR (g)
TS	P		°C	GWP-values	Q					
Refrigerant	R	S	kg							
CO2 equivalent	T		ton							



Dutch Thermal Engineering B.V.  
 Westerbroekstraat 18  
 7011 EX Gaanderen  
 Phone: +31(0)315-328311  
 E-mail: info@dte.eu



COUNTRY OF ORIGIN: The Netherlands

Figure 2.2

### 3 Transport and storage



These actions are general and have to be carried out, of course, if applicable for the application by qualified personal!

#### 3.1 Draining water from CoolMaster K and L



For packaging, transport and storage, first follow the following steps;

**Step 1:** Switch the main switch off.

**Step 2:** Close the filling connection (D1) (not present in machines, specified as **CoolMaster N, NF, NO, NOF, O and OF**)

**Step 3:** Drain the water tank of the cooling system by opening the ball valve.

**Step 4:** Dry clean all connections and water tank with a vacuum cleaner.

#### 3.2 Draining water/ Glycol mixture from CoolMaster N, NF, NO, NOF, O and OF



For packaging, transport and storage, first follow the following steps;

**Step 1:** Switch the main switch off.

**Step 2:** Drain the water tank of the cooling system by opening the ball valve.



**CAUTION!** For machines filled with a mixture of water and glycol (machines specified as **CoolMaster N, NF, NO, NOF, O and OF**), the excess mix from connection (E) may not be discharged into public sewers for environmental reasons. Instead, it should be collected in suitable containers and disposed of in accordance with applicable waste management regulations.

**Step 3:** Dry clean all connections and water tank with a vacuum cleaner.

#### 3.3 Packing, transport and storage instructions



**ATTENTION!** Before transport the machine has to be protected with the delivered cardboard box or has to be wrapped with bubble wrap. The machine has to be transported and stored vertically at all times on its fundament on the provided pallet!

The machine has to be placed vertically on its fundament at all times.



**ATTENTION!** In no way the machine can be stacked or overturned. This applies during transport and storing as well during repairs and commissioning. Even when the machine is not used it should be vertically at all times.



**ATTENTION!** Not following these instruction can cause severe damage to the machine.

Always use the correct type of transportation equipment, such as a pallet truck and a forklift truck.

## 4 Commissioning



These actions are general and have to be carried out, of course, if applicable for the application by qualified personal!



**CAUTION!** The Declaration of Incorporation of Partly Completed Machinery (if applicable) may not be put into service until a declaration of conformity to the provisions of the Machinery Directive 2006/42/EC is available for the finished machine in which it will be installed.

### 4.1 Installation CoolMaster K, N, NF, NO and NOF



Place the **CoolMaster** at a level position and at least **1 meter** from a wall. For the correct operation of the **CoolMaster** we recommend that you keep distance between the **CoolMaster** and the user as small as possible. The cooling water pipes between the **CoolMaster** and the user should not be longer than 20 meters.

### 4.2 Installation CoolMaster L, O and OF

Place the **CoolMaster** at a level position and at least **1 meter** from a wall. For the correct operation of the **CoolMaster** we recommend that you keep distance between the **CoolMaster** and the user as small as possible. The cooling water pipes between the **CoolMaster** and the user should not be longer than 20 meters. We recommend a max. distance between the **CoolMaster** and external condenser of 15 metres.

Place the external condenser at a level position and at least **1 meter** from a wall. The airflow direction of the condenser depends on which type external condenser installation. The space around the condenser can be calculated Figure 4.1 and Figure 4.2.

**Horizontal installation external condenser:**

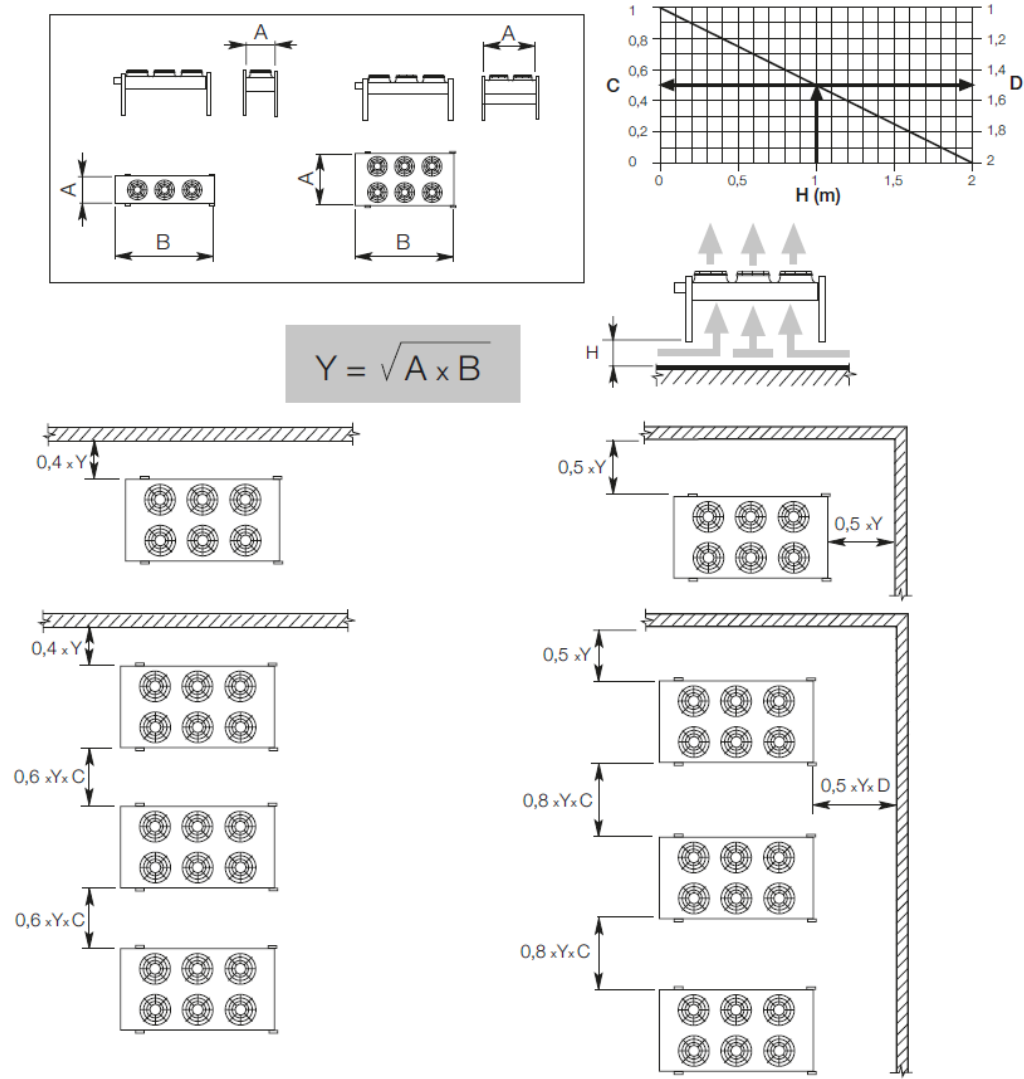

Figure 4.1

**Vertical installation external condenser:**

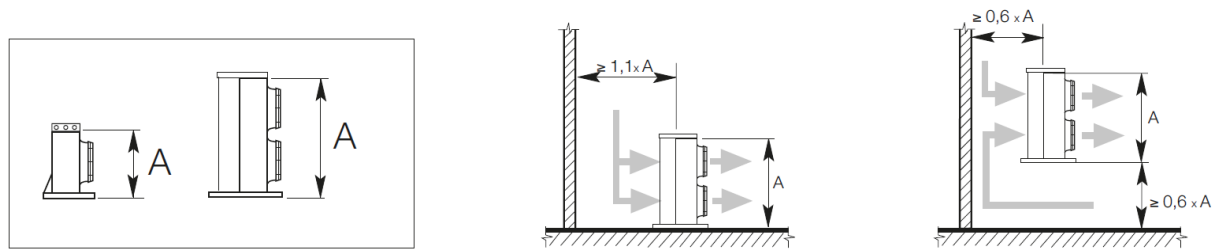

Figure 4.2

Connect the hot gas (P) and the liquid (Q) pipes.



**NOTE!** The *CoolMaster* and the external condenser are already factory filled with the right amount of refrigerant. The connection should only be made by specialized cool technical engineers.



Do not open the ball valves when the connections are not correctly made! Open the ball valves after vacuuming!



**NOTE!** The system is under pressure.

We recommend checking the connection for leaks after this installation.

In case the vertical distance between the external condenser and the *CoolMaster* is more than 3 meters there should be provide an so called “oil trap” in the hot gas pipes, (see Figure 4.3) At every next difference in level of 9 meters there should be provide an extra oil trap, (see Figure 4.4) The external condenser must be set up at the same height or higher than the *CoolMaster*.



**NOTE!** The connection between *CoolMaster* and the external condenser should not exceed 15 meters! (For piping diameters, see P&ID)



**NOTE!** THE PIPES BETWEEN THE *CoolMaster* AND THE EXTERNAL CONDENSER CAN BE HOT!

If these pipes accidentally can be touched it is recommendable to isolate these pipes.

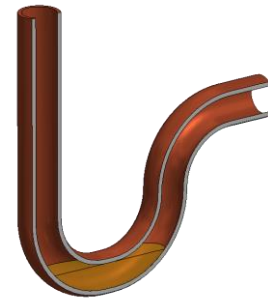

Figure 4.3

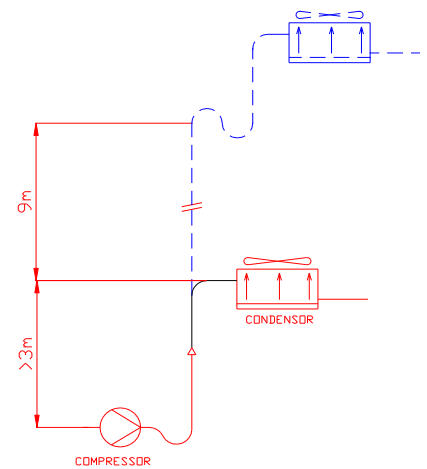

Figure 4.4



Connect the electrical cable(s) from the **CoolMaster** to the control switch (S) and fan(s) at the condenser. **These cable(s) may not touch the hot gas (P) and the liquid pipes (Q) of the condenser, as these pipes could be very hot!**

The cable(s) are already connected at the **CoolMaster**.  
For the connection of these cable(s), see electrical diagram.



Turn on main switch on control panel (G) to enable the crankcase heating of the compressors. At the first start up is not allowed to switch the **CoolMaster** immediately on by means of the control switch. There must be a delay time of at least 24 hours before the **CoolMaster** is switched on for the first time by means of the control switch or external start/stop. During this period the sump heater will evaporate the coolant out of the sump oil of the compressor.



**NOTE!** The **CoolMaster** with a crankcase heating may not be switched off using the main switch. Due to the crankcase heating which will be switched off. To prevent serious damage to the **CoolMaster**, the crankcase heating may never be switched off. When the **CoolMaster** is to be switched off, it must be done by means of the control switch which is located at the control panel (G).  
**EVEN ON LONG TERMS OF STANDSTILL!**



**WARNING!** In case of shutdown with control switch all parts in the control box will still be under tension.

If this will result into hazardous situations, in example maintenance to the **CoolMaster**, the **CoolMaster** needs to be switched off with the main switch.



**NOTE!** The Crankcase heating may also apply for **CoolMaster K, N, NF, NO and NOF**.

### 4.3 Connecting cooling water pipes\*



**ATTENTION!** Before making any connections to the *CoolMaster*, clean the external pipes. Dirt must be prevented from entering the *CoolMaster*. It may cause serious damage to the system and the *CoolMaster*.



**CAUTION!** The diameter of the pipes/tubes must correspond with the connections on the *CoolMaster*. The hoses **MUST** be reinforced with braided fibre to prevent kinking the hose.



**CAUTION!** When using metal pipes, the galvanic series of the materials used should be taken into account to prevent corrosion.

See for the connections chapter 2.1 on the *CoolMaster K, N, NF, NO and NOF*. For diameters see the corresponding P&ID.

See for the connections chapter 2.2 on the *CoolMaster L, O and OF*. For diameters see the corresponding P&ID.

The tubes must be suitable for use in the same conditions as those for which the *CoolMaster* is suitable (pressure and temperature). Consult the P&ID for this information.

Connect the following pipes:

- A and B: cooling water pipes between *CoolMaster* and the user.
- D1: If you wish to fill automatically (does not apply to machinery specified as *CoolMaster N, NF, NO, NOF, O and OF*).

#### Step 1:

1. Install the ball valve (BVS-1) on the cooling water inlet (A).
2. Install cooling water pipe between *CoolMaster* (BVS-1) and User, (see Figure 4.5).

*The ball valve (BVS-1) must be kept closed, unless otherwise indicated!*

#### Step 2:

1. Install the ball valve (BVS-2) on the cooling water outlet (B).
2. Install the ball valve (BVS-3) on the T-piece (central section).
3. Install the cooling water pipe between *CoolMaster* (on the T-piece) and the user, (see Figure 4.6)

*The ball valves (BVS-2 and BVS-3) must be kept closed, unless otherwise indicated!*



Figure 4.5



Figure 4.6



**Step 3:**

1. Connect the cooling water pipes between **CoolMaster** and user (BVS-1 and BVS-3), (see appendix §9.1)
2. Connect D1 to a water tap if you wish to fill automatically.  
(does not apply to machinery specified as **CoolMaster N, NF, NO, NOF, O and OF**)

**\*Ball valves are not supplied as standard!**

#### 4.4 Connecting drainage/overflow pipe (C+E)



**CAUTION!** For machines filled with a mixture of water and glycol (machines specified as *CoolMaster N, NF, NO, NOF, O and OF*), the excess mix from connection (E) may not be discharged into public sewers for environmental reasons. Instead, it should be collected in suitable containers and disposed of in accordance with applicable waste management regulations.

Connect the drainage/overflow pipe (C+E). To enable good outflow of superfluous water, the overflow pipe must be able to flow out into the open sewer without any foreseeable obstructions. The length of the overflow pipe should be kept to a minimum. The pipe should also flow downwards, from the perspective of the *CoolMaster* (C+E).

#### 4.5 Connecting refrigerant relief (V) if applicable



Connect refrigerant relief (V), if applicable. This connection is a safety valve which blows off refrigerant in unusual extreme conditions. Because refrigerant results to asphyxiation, the refrigerant relief (V) must be connected to the open air at a position where it is not dangerous! The refrigerant relief between the *CoolMaster* and the open air should be fixed tightly and must not be longer than 20 meters. The minimum internal diameter must correspond with the diameter of connection on the *CoolMaster*.

#### 4.6 Connecting power supply



**ATTENTION!** Work may only be carried out on the electrical installation of the *CoolMaster* by an authorised, professionally competent person.



**ATTENTION!** The *CoolMaster* must only be connected to a clockwise rotary field.



Turn off the main switch on the control panel (G).

Connect your electrical power supply cable to the appropriate terminals in the control box via the cable entry (F). Refer to the electro-technical diagram for the connection of the cable cores. Consult the diagram number as stated on the P&ID corresponding to the serial number of the *CoolMaster*.

Consult the type plate for the correct voltage.



**ATTENTION!** Ensure the voltage as stated on the type plate is also the voltage on each phase wire.



Of no less importance is the mains frequency (50 or 60 Hz) corresponding to the frequency on the type plate. The maximum voltage deviation is +6% and –10% from the voltage indicated on the type plate.

#### 4.7 Connecting external contacts

Also connect the electrical cables for the external contact(s).  
See for supplied electrical diagram.

#### 4.8 Water quality



**CAUTION!** The *CoolMaster* is not suitable for use with demineralized water or water containing high levels of minerals or iron.



**CAUTION!** The *CoolMaster N, NF, NO, NOF, O and OF* are only suitable for tap water of drinking water quality mixed with the correct ratio of a suitable anti-freeze (glycol).

The filling water which is used must be of good quality. It must at least be of drinking water quality and the water must not contain high levels of lime and/or iron, as it may cause serious damage.

You must check the water regularly.

The minimum filling pressure must be 2,5 bar.

See appendix §9.2 for extra information.

See appendix §9.3 for directive water quality.

## 4.9 Filling of (external) pipes and systems CoolMaster K and L

### Step 1:

1. All the connections must be made in accordance with §4.3.
2. Turn the air vent(s) in your system to “open”.  
(The venting must take place at the highest point(s) in pipe(s))



**CAUTION!** Do not use automatic air vents!

**CAUTION!** Filling procedure for machines designated CoolMaster K and L, (see chapter §4.11).

3. Connecting the filling water (min. 2.5 Bar) to BVS-3.
4. Turn the valve (BVS-3) to “open” position, (see Figure 4.7)

### Step 2:

Excess air will be released from the pipe(s) though the air release valve(s).

If the water spills from the air release valve(s), the external pipes/systems are filled with water.

1. Turn the ball valve (BVS-3) to “closed” position, (see Figure 4.8)
2. Turn the water fill line to “closed” position.
3. Remove the fill water line which is mounted on BVS-3.

### Step 3:

1. Turn the ball valve (BVS-1) to “open” position, (see Figure 4.9)
2. Turn the ball valve (BVS-2) to “open” position, (see Figure 4.10)

When these steps have been completed correctly, the entire system will be filled with water.



BVS-3  
Figure 4.7



BVS-3  
Figure 4.8



Figure 4.9



Figure 4.10

#### 4.10 Filling of (external) pipes and systems CoolMaster N, NF, NO, NOF, O and OF

**Step 1:**

1. The connections must be made in accordance with §4.3.

*The ball valve (BVS-1 and BVS-2) must be kept closed, unless otherwise indicated! (See Figure 4.11)*



**CAUTION!** Filling procedure for machines designated **CoolMaster N, NF, NO, NOF, O and OF**, (see chapter §4.12).

Filling set for mixture of water and glycol  
(The filling set is not supplied as standard)

**Step 2:**

1. Install the link (BVS-5) onto the ball valve (BVS-3)  
(Minimum pressure 2.5 bar), (see Figure 4.12)

See Figure 4.13 and Figure 4.14. For a complete image from the filling set. The mixture of water and glycol will be provided in the supplied tank. The ratio of the mixture is indicated in the relevant P&ID.



Figure 4.11

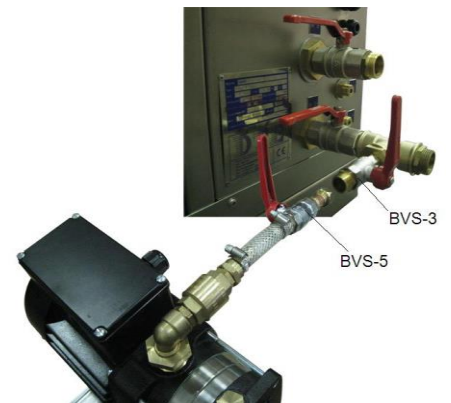

Figure 4.12



Figure 4.13

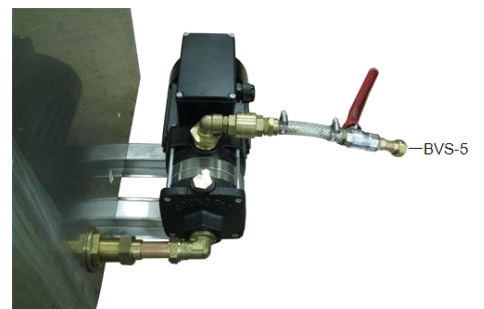

Figure 4.14



**Step 3:**

1. Turn the air release valve(s) to “open” (*It is essential that the air release(s) takes place at the highest point(s) in the pipe(s)*)

**CAUTION! Do not use automatic air release valves!**

2. Turn the ball valve (BVS-5) to “open” position, (see Figure 4.15).
3. Turn the ball valve (BVS-3) to “open” position, (see Figure 4.16 and Figure 4.17).

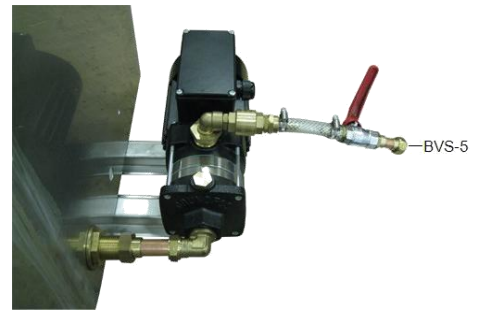

Figure 4.15



Figure 4.16

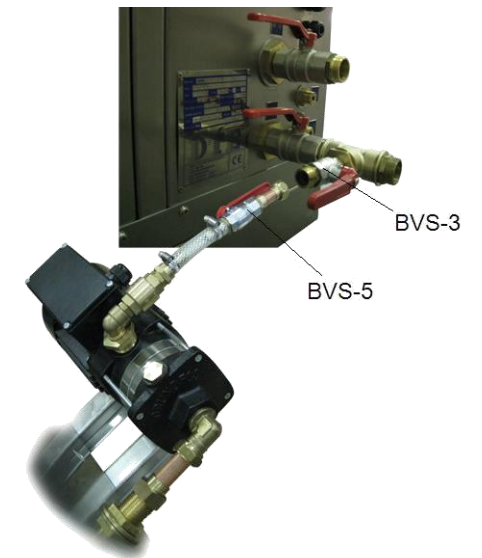

Figure 4.17

**Step 4:**

Excess air will be released from the pipe(s) through the air release valve(s).

If the water and glycol mixture spills from the air release valve(s), the external pipes/systems are filled with the water and glycol mix.

1. Turn the ball valve (BVS-3) to “closed” position, (see Figure 4.18)
2. Turn the air release valve(s) in your system to the “closed” position.
3. Turn the ball valve (BVS-5) to “closed” position.
4. Remove the ball valve (BVS-5), (see Figure 4.19)

**Step 5:**

1. Turn the ball valve (BVS-1) to “open” position, (see Figure 4.20)
2. Turn the ball valve (BVS-2) to “open” position, (see Figure 4.21)

When these steps have been completed correctly, the entire system will be filled with the water and glycol mixture.



Figure 4.18

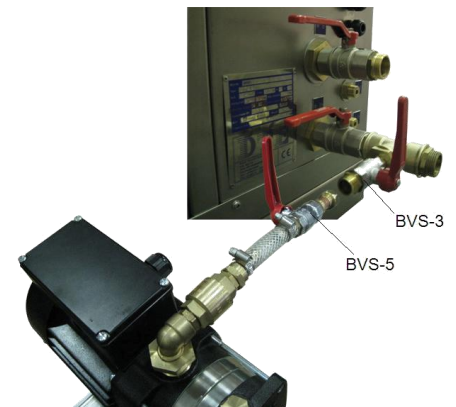

Figure 4.19



Figure 4.20



Figure 4.21



#### 4.11 Filling of the systems CoolMaster K and L



**CAUTION!** To add any chemicals or other substances, please consult the supplier.

Fill the **CoolMaster** with water (fill automatically or manually):

1. Auto fill (D1) (a power supply is required; a minimum filling pressure of 2.5 bar is required), (see Figure 4.22)
2. Manual fill (D2), (see Figure 4.23)

External systems must be filled via an external filling point. See chapter §4.9 for instructions.



Figure 4.22



Figure 4.23

#### 4.12 Filling of the systems CoolMaster N, NF, NO, NOF, O and OF



**CAUTION!** To add any chemicals or other substances, please consult the supplier.



**CAUTION!** To prevent the heat exchanger and/or other parts from freezing, the ratio of water to glycol must be weekly checked. An incorrect ratio or type of glycol may invalidate the warranty.

Fill the **CoolMaster** with the mix of water and glycol (using manual fill D2), (see Figure 4.24)



**CAUTION!** This mixture must be prepared beforehand. Filling with water first and adding the glycol afterwards or vice versa is prohibited. For the mixing ratio for this machine see the appropriate P&ID diagram.

External systems must be filled via an external filling point. See chapter §4.10 for instructions.



Figure 4.24

### 4.13 Deaerating



**CAUTION!** Do not start the pump before it has been de-aerated! (The pump can be turned off using motor circuit breaker, see enclosed electrical diagram)



**CAUTION!** Ensure the compressor is disabled when starting up for the first time! (The compressor can be switched off using motor circuit breaker, see enclosed electrical diagram)



**CAUTION!** If necessary, allow the crankcase heater to heat for at least 24 hours before use.

**Step 1:** Open the control box door, (see Figure 4.25)

**Step 2:** Switch off the compressor by turning off motor circuit breaker, see electrical diagram, (see Figure 4.26).

**Step 3:** Turn on the installation and let the pump run for 10 minutes to get the system deaerated.

**Step 4:** Now the entire system is air free, the compressor can be switched on again and the system can be used.

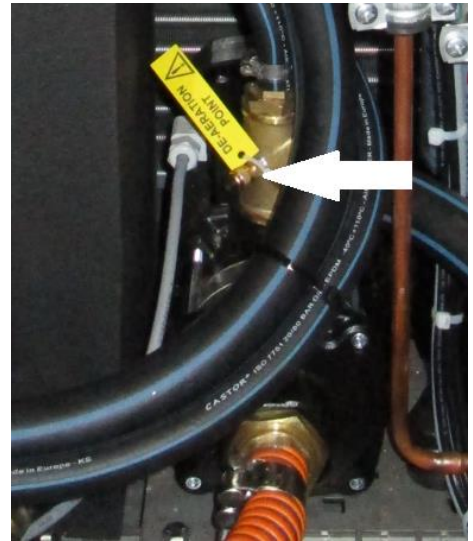

(De-aeration point)



Figure 4.25



Figure 4.26

#### 4.14 Setting thermostat (if applicable)



**CAUTION! SERVICE PANEL (I) MUST BE PLACED, BEFORE STARTING UP THE MACHINE!**  
(n.a. with external condenser).



**CAUTION! It is important that the values in the P&ID are adhered to otherwise damage to the compressor may occur! When temperatures set incorrectly the guarantee claim may expire!**



**CAUTION! When this machine is equipped with a bypass KV1-1, which is erected between water supply and water return pipe inside the *CoolMaster*. The minimum flow is already factory defined and sealed and may not be hanged!**

Switch on the main switch.

Switch on the external start/stop.

Set the thermostat to the correct value, which is on the front of the control panel (G).  
See enclosed P&ID for the settings.

The ***CoolMaster*** is now ready for use.

#### 4.15 Commissioning after long standstill



**CAUTION!** The Declaration of Incorporation of Partly Completed Machinery (if applicable) may not be put into service until a declaration of conformity to the provisions of the Machinery Directive 2006/42/EC is available for the finished machine in which it will be installed.



**CAUTION!** Machinery specified as **CoolMaster K, N, NF, NO and NOF**, first follow the steps from chapters §4.1 till 4.14.



**CAUTION!** Machinery specified as **CoolMaster L, O and OF**, first follow the steps from chapters §4.2 till 4.14.



**CAUTION! BEFORE OPENING THE MACHINE, ALWAYS ENSURE POWER SUPPLY IS COMPLETELY DISCONNECTED!**



**CAUTION!** Opening, closing or work in or at the control box for any reason, should always be performed by qualified personnel.

Check the machine for any defects including damages before starting the machine.



Clean the condenser fins with compressed air and/or vacuum cleaner/brush if necessary. **(ATTENTION: the fins can be sharp! Use the correct PPE) Always brush in the direction of the fins! (See Figure 4.27)**









Check the visual checks of the minimum inspection-interval schedule, see chapter §7.1.

For locked water pump after a long period of stand still, see appendix §9.4.



Figure 4.27

## 5 Alarm signals (if applicable)

	Fault →	Possible cause →	Check and solution
	<b>1. LP Alarm</b>	1.1. Pressure is too low in the system	1.1. Contact your supplier
	<b>2. HP Alarm</b>	2.1. Pressure is too high in the system 2.2. Place service panels	2.1. Check the condenser for dirt and Clean with compressed air if necessary 2.2. Contact your supplier if necessary 2.3. Resetting
	<b>3. Level Alarm</b>	3.1. Water level is too low	3.1. Check the water level on the gauge glass, refill if necessary 3.2. Check whether the machine refills automatically (if connected) 3.3. Check water inlet 3.4. Check valves 3.5. Check for leaks
	<b>4. Compressor alarm</b>	4.1. Thermal alarm or short-circuit compressor(s)	4.1. Check for short-circuit 4.2. Check for overload of compressor(s) 4.3. All phases present
	<b>5. Compressor oil Alarm</b>	5.1. No oil, or shortage of oil	5.1. Check sight glass 5.2. Check for leaks 5.3. Contact your supplier if necessary
	<b>6. Condenser Alarm</b>	6.1. Thermal alarm or short-circuit fan(s)	6.1. Check for short-circuit 6.2. Check for overload of fan(s) 6.3. All phases present
	<b>7. Water pump alarm</b>	7.1. Thermal alarm or short-circuit water pump(s)	7.1. Check for short-circuit 7.2. Check for overload of pump(s) 7.3. All phases present
	<b>8. Filling</b>	8.1. Filling system	8.1. Check liquid level 8.2. Refill manually if necessary. 8.3. In the event of malfunctions please contact the supplier

## 6 Fault analysis

<b>Have all checks and repairs performed by a certified technician!</b>		
<b>Fault →</b>	<b>Possible cause →</b>	<b>Check and solution</b>
<b>1. Unit does not start</b>	1.1. Faulty wiring 1.2. Components down to earth 1.3. Faulty main switch 1.4. Phase protection tripped (If present)	1.1. Check wiring and connections 1.2. Check and replace 1.3. Check and replace 1.4. Swap over the two power supply phases
<b>2. Fan(s) run but compressor will not start</b>	2.1. Faulty wiring 2.2. Faulty relay, or security 2.3. Faulty compressor	2.1. Check wiring and connections 2.2. Check components 2.3. Check and replace
<b>3. Compressor starts but no air is delivered over the condenser</b>	3.1. Fan loose on shaft 3.2. Faulty fan motor 3.3. Faulty wiring 3.4. Blocked air flow	3.1. Tighten fixing screw 3.2. Check and replace 3.3. Check wiring and connections 3.4. Clean the condenser
<b>4. Compressor switches off</b>	4.1. Electricity supply 4.2. Faulty thermostat 4.3. Faulty relay, or security 4.4. Internal security activated	4.1. Check electricity supply 4.2. Check and replace 4.3. Check and replace 4.4. Water and/or ambient temperature too high. Check cleanliness of condenser and clean it
<b>5. Unit does not cool</b>	5.1. Shortage of refrigerant 5.2. Faulty compressor 5.3. Faulty thermostat 5.4. Faulty pump	5.1. Refill 5.2. Check and replace 5.3. Check and replace 5.3. Check and replace
<b>6. Water pump gives no water</b>	6.1. Water pump not de-aerated 6.2. Impeller of water pump is stuck 6.3. Faulty relay, or security	6.1. De-aerate water pump 6.2. See appendix §9.4 6.3. Check components
<b>7. Shortage of refrigerant</b>	7.1. Leak in the system	7.1. Check the system for leakage and repair

## 7 Maintenance and cleaning



### All proceedings must be performed:

- By expert qualified personnel
- With a user manual under easy reach
- Separated from the electrical network and guards against arming!

### WARNING!

Weekly checks, User maintenance may be performed by the user of the machine.

All maintenance proceedings (with an interval >weekly) serve must always be performed by qualified personnel!



**A technical person with managerial position is responsible for determination of the maintenance interval. NEN3140 prescribes that this person must be the Installation manager.**



**The determination of these interval serves with reference to:**

- User manual
- Authority (competent bodies, policy, regulation etc.)
- Conditions of parts (exposure and/or corrosion)
- Results of previous inspections



**DTE recommends a minimum inspection interval as given in chapter (§7.1).**



If a problem and/or advise is needed from our technical staff, please always mention:

- Serial number
- Ambient temperature
- What is shown at the display of the thermostat
- What is the setpoint of the thermostat
- Which alarm signals are given

By mention these points, a quick solution of the problem can be given.

All maintenance jobs should be executed when the **CoolMaster** is complete tensionless.

**NOTE:** The minimal distance of service area should be 1,30 meter.

### **Dutch Thermal Engineering B.V.**

Westerbroekstraat 18  
7011 EX Gaanderen  
Tel.: +31(0)315-328311  
E-mail: [service@dte.eu](mailto:service@dte.eu)  
Website: <https://dte.eu/>



## 7.1 Minimum Inspection-interval scheme



All inspections should be performed by an authorized technician!



**CAUTION! BEFORE OPENING THE MACHINE, ALWAYS ENSURE POWER SUPPLY IS COMPLETELY DISCONNECTED!**

Inspection points	Inspection interval			
	Weekly	monthly	Every 6 months	Every 12 months
<b>Mechanical</b>				
Visual check on damage outside of the unit	X			
Visual check fans motor(s) and fan blade(s) on damage and prevalence	X			
Visual (and auditive) check on defects	X			
Visual check mixing ratio water/glycol (only <b>CoolMaster N, NF, NO, NOF, O and OF</b> )	X			
Visual check water level of the water tank at the sight glass (P) or (S)	X			
Visual the by-pass flow of the water pump <b>inside</b> the water tank	X			
Visual check water quality		X		
Visual check for water leaks		X		
Cleaning condenser by using with compressed air or vacuum cleaner ( <b>ATTENTION! the fins can be sharp! Use the correct PPE</b> ) Always brush in the direction of the fins!		X		
Cleaning the compressor with damp cloth.				X
Visual check quality of the insulation material				X
<b>Electrical</b>				
Visual check power consumption			X	
Visual check all wiring for damage			X	
Visual check electrical components and contactors			X	
Visual check all potential equalisation and earthings				X

**The maintenance and leak-tightness checks should be carried out, according to the local legislation.**

**For the Dutch guidelines, the maintenance and leak-tightness checks should be carried out according to the table below.**

Only certified companies employing qualified technicians are allowed to carry out refrigeration work or inspections of refrigeration installations.

CO2-equivalent	Number of inspections each year	NOTE: for installations with a leak detection system, the frequency can be halved
5 – 50 ton CO2-equivalent:	1 x	
50 – 500 ton CO2-equivalent:	2 x	
> 500 ton CO2-equivalent * :	4 x	

*\* automatic leak detection mandatory*

**CO2 equivalent content is stated on the nameplate and corresponding P&ID.**

## 7.2 Cleaning of the machine



**CAUTION! ONLY APPLIES TO THE EXTERIOR CASING!**



**Step 1:** Before cleaning the machine, make sure you completely disconnect the power supply.



**Step 2:** To clean the machine use a soft brush, with lukewarm water with a non-aggressive cleaner.

**Step 3:** Then rub the machine dry with a soft, dry cloth. Unless explicitly stated otherwise the machine must not be cleaned with a high-pressure cleaner and/or other powerful water jets!

**Step 4:** For additional cleaning instructions, see appendix §9.2 Water Treatment.

## 8 Removal

The **CoolMaster** consists primarily of stainless steel, copper, brass and aluminium. The **CoolMaster** is also compressed with a refrigerant which is specified in the “P&ID” and the relevant safety data sheet.

Removal of the **CoolMaster** must be carried out in accordance with local or national legislation. Contact your government for instructions.

## 9 Appendix

### 9.1 Connection diagram filling the system

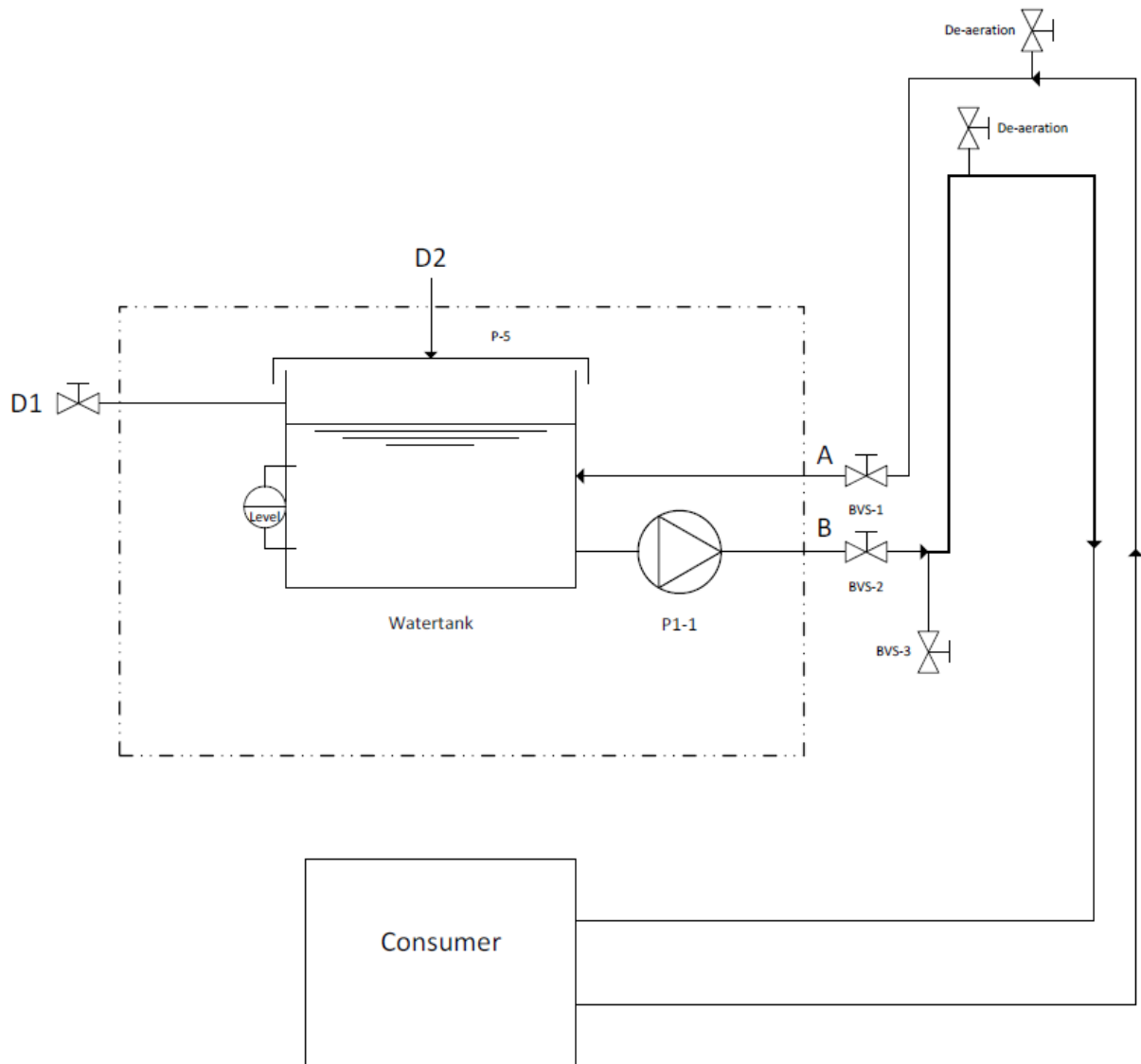

Figure 9.1

## 9.2 Water treatment

### INTRODUCTION

Semi-closed and closed cooling systems are used in many processes.

An efficient and effective cooling system is needed for a process to function without problems.

Generally such cooling systems contain between 0.5 and 5.0 m<sup>3</sup> water, which is normally topped up with tap water. The tap water available is often, technically speaking, of poor quality:

- contains limescale and/or
- is corrosive

The system may contain many different materials with which the cooling water comes into contact. Such as:

- steel/cast iron
- copper/brass
- aluminium
- synthetics/sealants

### PROBLEM DEFINITION

Corrosion problems can occur in cooling systems, which have different causes.

The presence of different materials can result in galvanic corrosion, which is where the least precious metal is dissolved. The action of oxygen on iron and steel causes oxygen corrosion and the formation of iron oxide or silt. Natural silt accumulation can lead to “under deposit corrosion”. High flow-speeds can lead to erosion corrosion. The quality of the cooling water plays a significant role in this.

### GENERAL MEASURES

Contamination	Measure
Mechanical contamination caused by iron oxides or silt	Install filters, depending on contamination
High hardness	Soften water via ion exchange
Minor contamination caused by presence of oxides and hardness	Use water treatment in the form of hardness stabilisation and corrosion inhibitors
Biological contamination caused by presence of algae and slime bacteria	Use water treatment in the form of biocides

## **WATER QUALITY**

The water quality should be kept within the values below for closed or semi-close systems.

## **WATER TREATMENT**

Specific water treatment should be used if one or more values cannot be maintained or achieved.

Water treatment products can be used for a wide variety of applications in this case. DTE has a water treatment in the form of PollutionMaster. This product can optionally be supplied. If the temperature of the water exceeds approx. 40°C, (partial) water softening must in general be applied.

A complete water treatment proposal can be drawn up after the water quality has been assessed on site.

## **CLEANING**

If the cooling system is already very contaminated, we recommend cleaning the system with a suitable cleaning product. The cleaning solution can be pumped around using the system pump or an cleaning pump. For the best cleaning result, at least some flow should be established across all components. The cleaning progress can be monitored through visual inspection and using pH test strips.

Systems with considerable biological contamination should be rinsed thoroughly first. A bio-dispergator can also be used for this purpose.

The cleaning method and costs will be assessed and determined per situation.

**Note:** You can contact DTE anytime.



### 9.3 Guideline for water quality in DTE installations

Water quality for use in all DTE installations is prescribed in this general guideline. Water quality used in DTE installations should meet this standard at all times.

Standard values for water quality:

- Acidity: PH 7 < PH 9,5
- Chloride: < 50mg / L
- Conductivity: 150  $\mu$ S < 350 $\mu$ S
- Bicarbonate (HCO<sub>3</sub>): 80mg/L < 100mg/L
- Hardness: 2dH° < 8dH°

This directive is a general directive which also applies to systems in which water with a percentage of glycol is used.

In cases where a water-glycol mixture is to be applied, the quality of water must first be analysed to be ensured the water quality is within the norm values. Subsequently, a water-glycol mixture may be prepared that must be tested on mixing ratio before use.

In the system the absorption of oxygen must be prevented to keep the hydrogen carbonate (HCO<sub>3</sub>) level within the acceptable range. In case of doubt, this should be tested with a sufficient frequency.

## 9.4 Manual for locked water pump after a long period of stand still



**CAUTION! BEFORE OPENING MACHINE, ALWAYS ENSURE POWER SUPPLY IS COMPLETELY DISCONNECTED!**

DTE uses reputable components in its products, whereby DTE will reduce the risk of faults in its machines. This also applies to the water pumps. These pumps are made with a stainless steel fan, a high quality pump house and a "Mechanical seal" to seal the axis. The mechanical seal is a high quality axis seal made from polished hard metal, and all contact surfaces are polished. This will guarantee a good sealing even under the toughest operating circumstances. The mechanical seal will lubricate itself by means of a thin liquid layer of the pumped fluid.

When the machine has not been used for a long period there is a chance that the water pump will not run.

### **Cause:**

The cause of this fault may be cohesion between the polished contact surfaces of the mechanical seals. The seals "stick together".

### **Solution:**

- This problem is easily solved by rotating the pump axis by hand.
- The axis of the Grundfos CM pump can be rotated by removing the protection cover by the two screws at the side of the fence, (see Figure 9.2).
- You can now rotate the engine fan by hand, (see Figure 9.3).
- The sticking together has now been broken and the machine can be started.



**CAUTION! MAKE SURE TO REPLACE THE ROSTER, OTHERWISE THE PUMP ENGINE WILL NOT BE COOLED PROPERLY!**



Figure 9.2

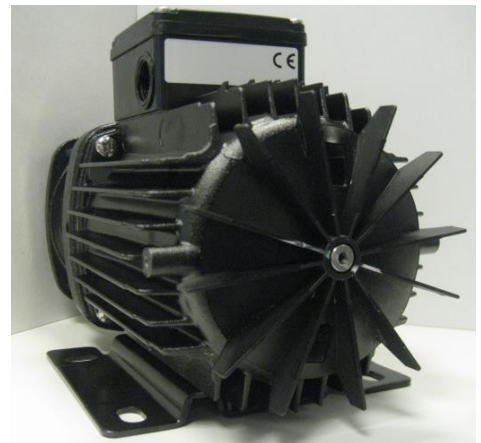

Figure 9.3

### Checking the direction of rotation

#### - For the Grundfos CM pump:

The description below applies to three-phase motors only. The motor fan cover has an installation indicator, (see Figure 9.4) Based on the motor cooling air, it indicates the direction of rotation of the motor. Before you start the motor for the first time or if the position of the installation indicator has been changed, check that the installation indicator is working properly for instance by moving the indicator field with a finger. To determine whether the direction of rotation is correct or wrong, compare the indication with the table below.

Indicator field	Direction of rotation
Black	Correct
White/reflecting	Wrong*

\* To reverse the direction of rotation, switch off the power supply and interchange any two of the incoming supply wires.

You can place the indicator in various positions on the motor, but do not place it between the cooling fins close to the screws that hold the fan cover. The correct direction of rotation is also shown by arrows on the motor fan cover.

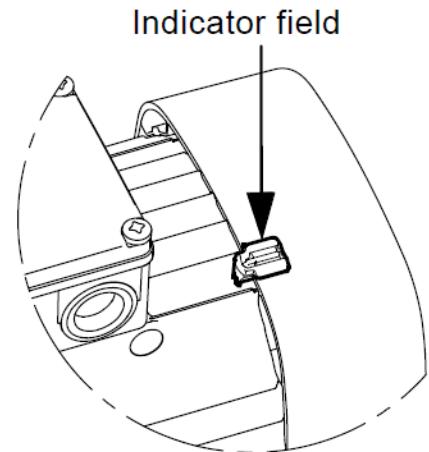

Figure 9.4

## 9.5 User manual thermostat (if applicable)\*

KLT12ID:

### SETPOINT CHANGE

- Push “SET” once (set point will be displayed flashing).
- Change the set point by pressing “UP” and “DOWN”.
- Confirm the changed set point with “SET”.

### DISPLAY MESSAGES:

In normal operation the probe temperature selected by P5 will be displayed. But the following messages may also appear:

- “Err” - Memory reading error
- “Erp” - Probe error, not viewed in display
- “Eri” - Internal parameter error. In this case, enter the above DTE-configuration
- “ALH” - High temperature alarm
- “ALL” - Low temperature alarm (temperature is 5 degrees lower then “SET”)
- “ALE” - External alarm
- “AEL” - High and external alarm
- “000” - Probe open
- “---” - Probe short-circuited
- “DON” - Defrosting activated
- “DOF” - Defrosting de-activated, or cannot be done
- “CON” - Continuous cold cycle
- “COF” - Continuous cold cycle de-activated, or cannot be done
- “-d-” - Thermostat on defrosting
- “OFF” - Thermostat switched OFF, can be switched on by pressing the “UP” and “DOWN”-button simultaneously for at least 8 seconds

### ONDERHOUD

- Cleaning:  
Clean the surface of the controller with a soft, damp cloth. **NEVER use abrasive detergents, alcohol or solvents**
- Repairs/Programming  
All repairs and the programming of the thermostat must be carried out by authorised professional.

\*When deviating from the standard, the user manual of the thermostat will be sent as an appendix!

## 9.6 Instructions of Partly Completed Machinery (if applicable)



**CAUTION! ONLY APPLICABLE TO THE OUTSIDE OF THE CASING!**



**CAUTION!** When there is an Partly Completed Machinery, the machine must be equipped with an external thermal protection and main switch with the correct range to ensure safety!



**CAUTION!** The Declaration of Incorporation of Partly Completed Machinery may not be put into service until a declaration of conformity to the provisions of the Machinery Directive 2006/42/EC is available for the finished machine in which it will be installed.

## 9.7 Declaration of conformity\*

### EU declaration:

Manufacturer: D.T.E. B.V.  
Address: Westerbroekstraat 18  
7011 EX GAANDEREN / HOLLAND



Hereby certifies that:

The **CoolMaster** meets the requirements of the Machinery Directive (Directive 2006/42/EC, as amended), and the national legislation implementing this Directive;

Meets the provisions of the following other EC directives.

- 2014/35/EU Low voltage directive
- 2014/30/EU EMC-directive
- 2014/68/EU Pressure Equipment Directive (PED)

And certify that:

The following (parts of) harmonized standards are applied:

- NEN-EN-IEC 60204-1:2018
- NEN-EN-ISO 12100:2010
- NEN-EN 378-2:2016
- NEN-EN-ISO 13857:2019

The following (parts of) national technical standards and specifications are used:

- Regulation EU 517/2014

Made in Gaanderen on 01-01-2024

.....  
M. Brill

Managing director

**\*This is an example, the original declaration will delivered with the machine!**

**UKCA declaration:**

Manufacturer: D.T.E. B.V.  
Address: Westerbroekstraat 18  
7011 EX GAANDEREN / HOLLAND



Hereby certifies that:

The **CoolMaster** meets the requirements of the Machinery Directive (Directive Supply of Machinery (Safety) Regulations 2008, as amended), and the national legislation implementing this Directive;

Meets the provisions of the following other UKCA directives:

- Electrical Equipment (Safety) Regulations 2016
- Electromagnetic Compatibility Regulations 2016
- Pressure Equipment (Safety) Regulations 2016

And certify that:

The following (parts of) harmonized standards are applied:

- NEN-EN-IEC 60204-1:2018
- NEN-EN-ISO 12100:2010
- NEN-EN 378-2:2016
- NEN-EN-ISO 13857:2019

The following (parts of) national technical standards and specifications are used:

- Regulation EU 517/2014

Made in Gaanderen on 01-01-2024

.....  
M. Brill  
Managing director

**\*This is an example, the original declaration will delivered with the machine!**

## 9.8 Guarantee

One or more components in this **CoolMaster** are sealed. Breaking these seals or adjusting components which are not sealed, may void your guarantee. Always contact your supplier. When claiming one or more components under the guarantee, these components must be returned to the supplier uncleaned and in their original state.

Otherwise, the guarantee conditions on this machine apply as described in the general conditions of delivery and payment. These were deposited at the Chamber of Commerce in Arnhem on 05-06-1989, a copy of which is available upon request.





## **9.10 Technical information\***

- **Machine drawing**
- **P&ID**
- **Spare parts list**
- **Electrical diagram**
- **Safety data sheet refrigerant**
- **Safety data sheet monoethylene glycol (MEG)**
- **Other**

**\*Technical information is sent as an attachment to the technical operating instructions!**