



CoolMaster K2



CoolMaster S1/S2



CoolMaster M1



CoolMaster L1



CoolMaster X1

PERFECT SOLUTIONS FOR
INDUSTRIAL PROCESS WATER SYSTEMS

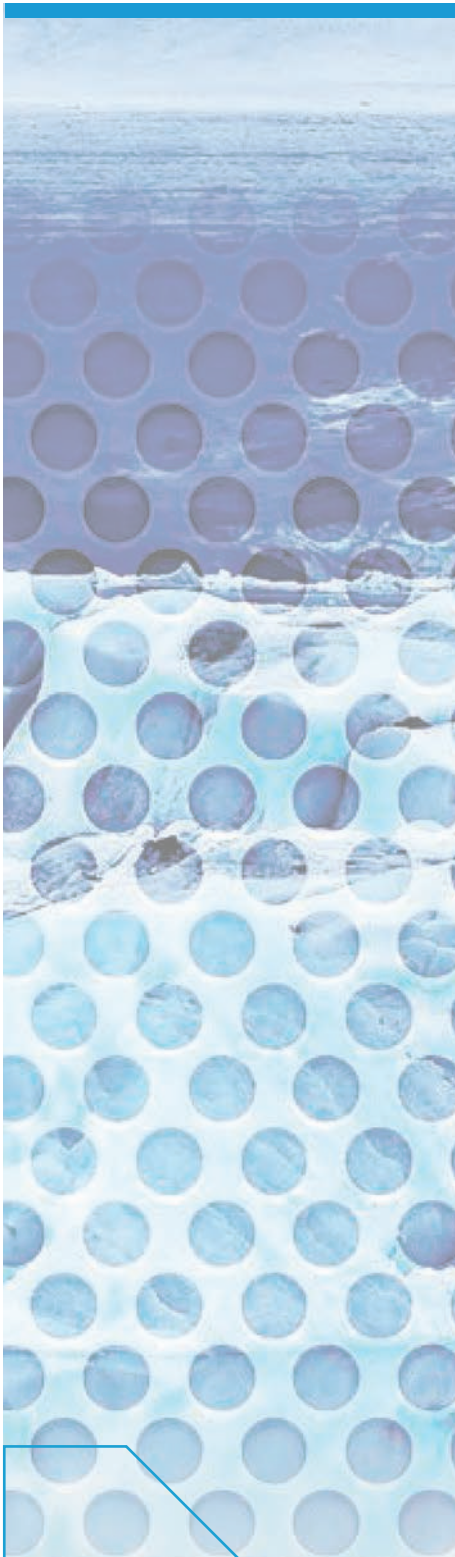

DTE CoolMasters are a range of ready-to-use cooling machines with built-in water tank, pump, condenser and controls. Depending on your wishes, our machines can be fitted with a large number of options such as tank heating, recuperation function, extra pump for secondary circuit etc. The CoolMaster design is based on components of leading brands which are carefully selected and calculated by special designed programmes DTE uses for this purpose. Therefore it is possible to house maximum cooling capacity in a minimum of space but still keep the components easy to access or to exchange.

To guarantee long life of the CoolMaster, DTE chooses consciously for durable materials and a robust stainless steel housing with rubber floor supports (K2 series) which, when needed, are easy removable to enable direct mounting onto customers frame.

The insulated stainless steel water tank in the CoolMaster is completely sealed to prevent any possible algal growth cause dby the incidence of light. Furthermore, the warm air produced by the condenser does not remain in the CoolMaster, but fades directly by a powerful axial fan. All CoolMasters are equipped with high efficiency plate heat exchanger evaporators which give high cooling capacity and very low energy consumption.

These important DTE constructional features indicate the quality and reliability of the CoolMaster. To prove our quality, all DTE products are developed and constructed in accordance with ISO 9001 and fully meet all European safety and quality directives such as 2006/42/EG, EN-ISO 12100:2010, EN-IEC 60204-1:2006, EN378-3:2016 and PED directive 2014/68/EU. On request we can build the CoolMaster according to UL/CSA regulations or ATEX-proof.

All machines are provided with testing certificates, instruction card and operating & maintenance manual. All certificates issued according European and local laws governing construction of refrigeration.

Main components in the CoolMaster are:

- Stainless steel plate heat exchanger evaporator (for machines \geq 5kW)
- Tube coil heat exchanger (evaporator) made of stainless steel (K2 series)
- Digital temperature controller with adjustable limitation and display to read measured values.
- A pressure limited thermostatic expansion valve.
- Industrial multi-stage centrifugal pump with impellers, shaft and other key components of stainless steel.
- By-pass for water pump protection.
- Hermetically sealed & suction gas-cooled compressor.
- Air-cooled condenser specially designed by DTE, fitted with copper piping and aluminium vanes.
- Industrial axial fan which vertically evacuates the direct hot condenser air.
- A closed water tank of stainless steel, provided with insulation, float for automatic refill, manual filling device and sight glass.
- Switch box equipped with all necessary protections.
- Connection for external start/stop (volts-free contact)

Furthermore all connections are fitted on 1 side of the machine for easy connection.



To meet all of our customers wishes DTE also offers customized cooling machines which are calculated and built according to your specifications. The modular construction of our CoolMaster allows fast and simple adaptation to your specifications. DTE has almost all components for extra features available on stock.

Some of these options are:

- Full compliance with country dependent standards and regulations.
- Adaptation to all voltages and frequencies.
- Housing fitted with wheels instead of floor supports.
- Adaptation to extreme environmental conditions.
- Remote control for temperature adjustment and/or temperature readout.
- ATEX Zone 1 and 2 systems.
- Integration of water-cooled instead of air-cooled condenser.
- Water piping made of copper or stainless steel.

Please contact us to find the right solution for your cooling problem!



Type Number	* Cooling capacity at 15° C	* Cooling capacity at 5° C	Voltage/ Frequency	** Circulation cooling water	* Rated power input	* Rated current	*** Max. current	Water tank volume	Air Quantity	
Range K2	Watt	Watt	V/Hz	l/h	kW	Amp.	Amp.	Liters	m³/h	~ Kg
K-001.0	990	710	1N220-240/50	CM3-3	0,85	4,35	5,05	23	1.180	80
K-001.7	1.720	1.270	1N220-240/50	CM3-3	0,87	4,42	5,17	23	1.180	80
K-003.6	3.550	2.520	1N220-240/50	CM3-3	1,33	6,27	8,47	23	1.180	81
K-004.9	4.850	3.510	1N220-240/50	CM3-3	1,90	9,07	11,47	23	1.180	89
Range S1	Watt	Watt	V/Hz	l/h	kW	Amp.	Amp.	Liters	m³/h	~ Kg
K-004.7	4.690	3.140	3x380-415/50	670	1,64	8,39	11,89	45	2.600	160
K-005.5	5.470	3.930	3x380-415/50	780	1,71	8,54	12,04	45	2.600	160
K-007.6	7.630	5.410	3x380-415/50	1.090	2,54	6,98	9,04	45	2.600	176
Range S2	Watt	Watt	V/Hz	l/h	kW	Amp.	Amp.	Liters	m³/h	~ Kg
K-008.9	8.950	6.370	3x380-415/50	1.280	3,60	6,69	8,75	45	5.210	197
K-012.1	12.140	8.110	3x380-415/50	1.730	4,25	7,95	11,35	45	5.210	200
K-014.5	14.530	10.100	3x380-415/50	2.080	4,67	8,35	11,75	45	5.210	200
Range M1	Watt	Watt	V/Hz	l/h	kW	Amp.	Amp.	Liters	m³/h	~ Kg
K-017.4	17.370	12.420	3x380-415/50	2.480	5,90	13,06	20,56	84	5.210	299
Range L1	Watt	Watt	V/Hz	l/h	kW	Amp.	Amp.	Liters	m³/h	~ Kg
K-019.3	19.260	13.530	3x380-415/50	2.750	5,51	13,21	21,51	140	10.420	392
K-023.4	23.370	16.320	3x380-415/50	3.340	6,46	14,61	24,51	140	10.420	394
K-027.8	27.790	19.890	3x380-415/50	3.970	7,84	16,41	21,51	140	10.420	392
K-032.1	32.110	23.370	3x380-415/50	4.590	9,64	19,31	24,51	140	10.420	394
Range X1	Watt	Watt	V/Hz	l/h	kW	Amp.	Amp.	Liters	m³/h	~ Kg
K-037.4	37.370	26.320	3x380-415/50	5.340	9,82	23,77	39,77	140	15.630	608
K-044.7	44.740	31.470	3x380-415/50	6.390	12,23	26,87	45,97	140	15.630	613
K-050.5	50.530	36.840	3x380-415/50	7.220	15,77	30,37	39,77	140	15.630	608

* At an ambient temperature of 27°C **Pressure pump output, see pump curve ***Maximum permissible load.
Conversion values: 1W = 1J/s = 0,86 kcal/h. Technical specifications subject to change.

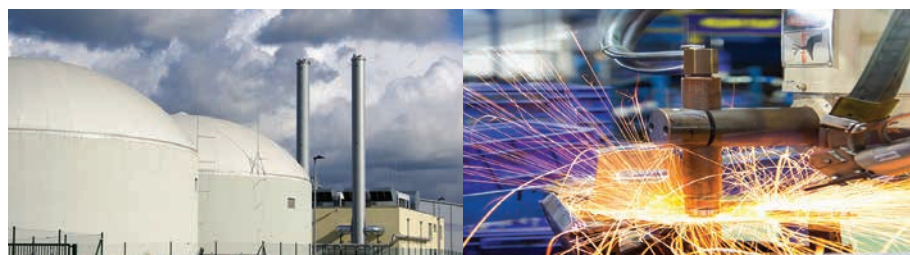

CAPACITIES OVERVIEW

Ambient Temperature	27°C				30°C				32°C			
Cooling water temperature	5° C	10°C	12°C	15°C	5°C	10°C	12°C	15°C	5°C	10°C	12°C	15°C
Range K2	Watt											
K-001.0	710	823	884	990	690	821	881	927	663	789	849	892
K-001.7	1.270	1.429	1.536	1.720	1.234	1.426	1.531	1.610	1.187	1.371	1.475	1.550
K-003.6	2.520	2.950	3.170	3.550	2.450	2.870	3.080	3.240	2.360	2.760	2.970	3.120
K-004.9	3.510	4.120	4.440	4.850	3.410	4.010	4.310	4.540	3.280	3.860	4.150	4.370
Range S1	Watt											
K-004.7	3.140	3.870	4.190	4.690	3.030	3.720	4.030	4.510	2.930	3.610	3.930	4.440
K-005.5	3.930	4.660	4.980	5.470	3.820	4.510	4.820	5.300	3.720	4.400	4.720	5.190
K-007.6	5.410	6.460	6.940	7.630	5.200	6.250	6.730	7.410	5.100	6.150	6.570	7.250
Range S2	Watt											
K-008.9	6.370	7.580	8.110	8.950	6.160	7.320	7.790	8.580	6.000	7.160	7.630	8.370
K-012.1	8.580	10.370	11.050	12.140	8.420	10.000	10.680	11.740	8.160	9.740	10.420	11.420
K-014.5	10.110	12.160	13.050	14.530	9.740	11.740	12.630	14.000	9.470	11.420	12.260	13.630
Range M1	Watt											
K-017.4	12.420	14.740	15.740	17.370	12.050	14.320	15.260	16.740	11.740	13.950	14.950	16.420
Range L1	Watt											
K-019.3	13.530	16.210	17.370	19.260	13.110	15.790	16.950	18.740	12.840	15.470	16.630	18.420
K-023.4	16.320	19.580	21.050	23.370	15.790	19.050	20.420	22.630	15.470	18.630	20.000	22.210
K-027.8	19.890	23.680	25.260	27.790	19.160	22.840	24.420	26.840	18.740	22.320	23.790	26.320
K-032.1	23.370	27.470	29.260	32.110	22.530	26.530	28.320	30.950	22.000	25.890	27.580	30.210
Range X1	Watt											
K-037.4	26.320	31.470	33.680	37.370	25.580	30.530	32.630	36.320	25.050	30.000	32.110	35.260
K-044.7	31.470	37.890	40.530	44.740	30.530	36.320	38.950	43.160	29.790	35.790	38.420	42.110
K-050.5	36.840	43.160	45.790	50.530	35.260	41.580	44.210	48.420	34.740	40.530	43.160	47.370



CAPACITIES OVERVIEW

Ambient Temperature	35°C				40°C				45°C			
Cooling water temperature	5° C	10°C	12°C	15°C	5°C	10°C	12°C	15°C	5°C	10°C	12°C	15°C
Range K2	Watt											
K-001.0	635	752	808	851	585	691	744	783	-----	-----	-----	-----
K-001.7	1.136	1.306	1.405	1.479	1.046	1.201	1.292	1.360	-----	-----	-----	-----
K-003.6	2.260	2.640	2.840	2.990	2.080	2.430	2.610	2.750	-----	-----	-----	-----
K-004.9	3.140	3.690	3.960	4.170	-----	-----	-----	-----	-----	-----	-----	-----
Range S1	Watt											
K-004.7	2.770	3.450	3.720	4.090	2.510	3.140	3.450	3.820	-----	-----	-----	-----
K-005.5	3.560	4.240	4.510	4.980	3.300	3.930	4.240	4.610	-----	-----	-----	-----
K-007.6	4.880	5.880	6.310	6.990	-----	-----	-----	-----	-----	-----	-----	-----
Range S2	Watt											
K-008.9	5.740	6.840	7.320	8.050	5.370	6.420	6.840	7.580	-----	-----	-----	-----
K-012.1	7.840	9.370	10.000	11.000	-----	-----	-----	-----	-----	-----	-----	-----
K-014.5	9.050	11.000	11.790	13.110	-----	-----	-----	-----	-----	-----	-----	-----
Range M1	Watt											
K-017.4	11.800	13.470	14.420	15.890	-----	-----	-----	-----	-----	-----	-----	-----
Range L1	Watt											
K-019.3	12.470	15.000	16.110	17.890	11.790	14.210	15.260	16.950	11.050	13.370	14.370	16.000
K-023.4	15.000	18.000	19.370	21.580	14.110	17.050	18.320	20.320	13.260	16.000	17.160	19.050
K-027.8	18.000	21.470	22.950	25.370	-----	-----	-----	-----	-----	-----	-----	-----
K-032.1	21.160	24.950	26.530	29.050	-----	-----	-----	-----	-----	-----	-----	-----
Range X1	Watt											
K-037.4	24.210	29.050	31.050	34.210	22.840	27.370	29.370	32.630	-----	-----	-----	-----
K-044.7	28.740	37.740	36.840	41.050	27.050	32.630	34.740	38.420	-----	-----	-----	-----
K-050.5	-----	-----	-----	-----	-----	-----	-----	-----	-----	-----	-----	-----



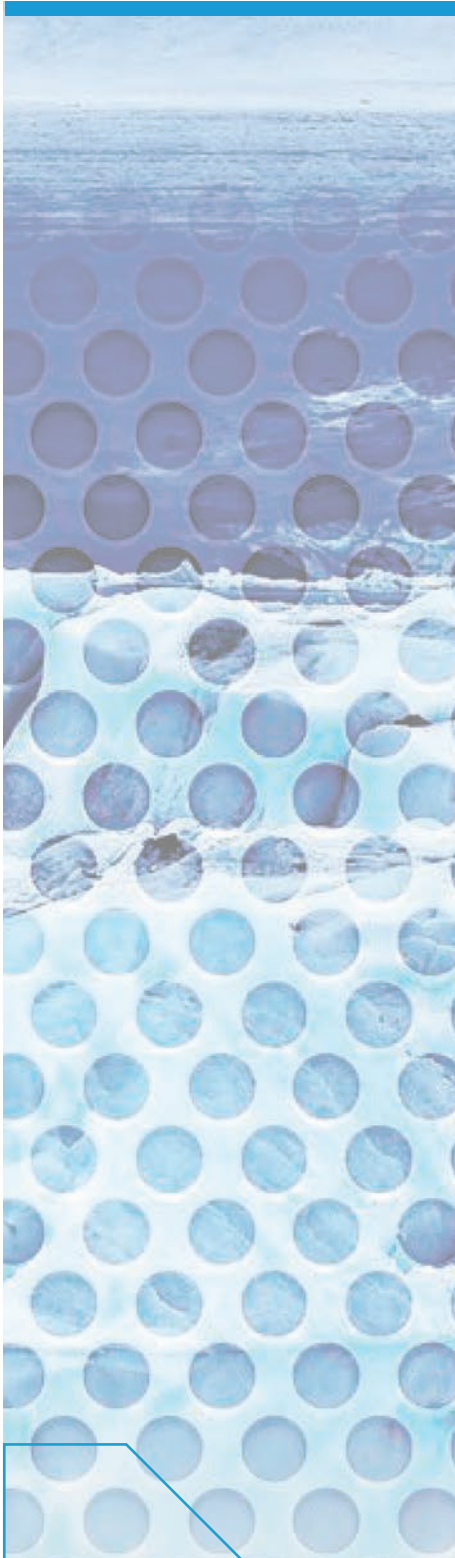

K2 series

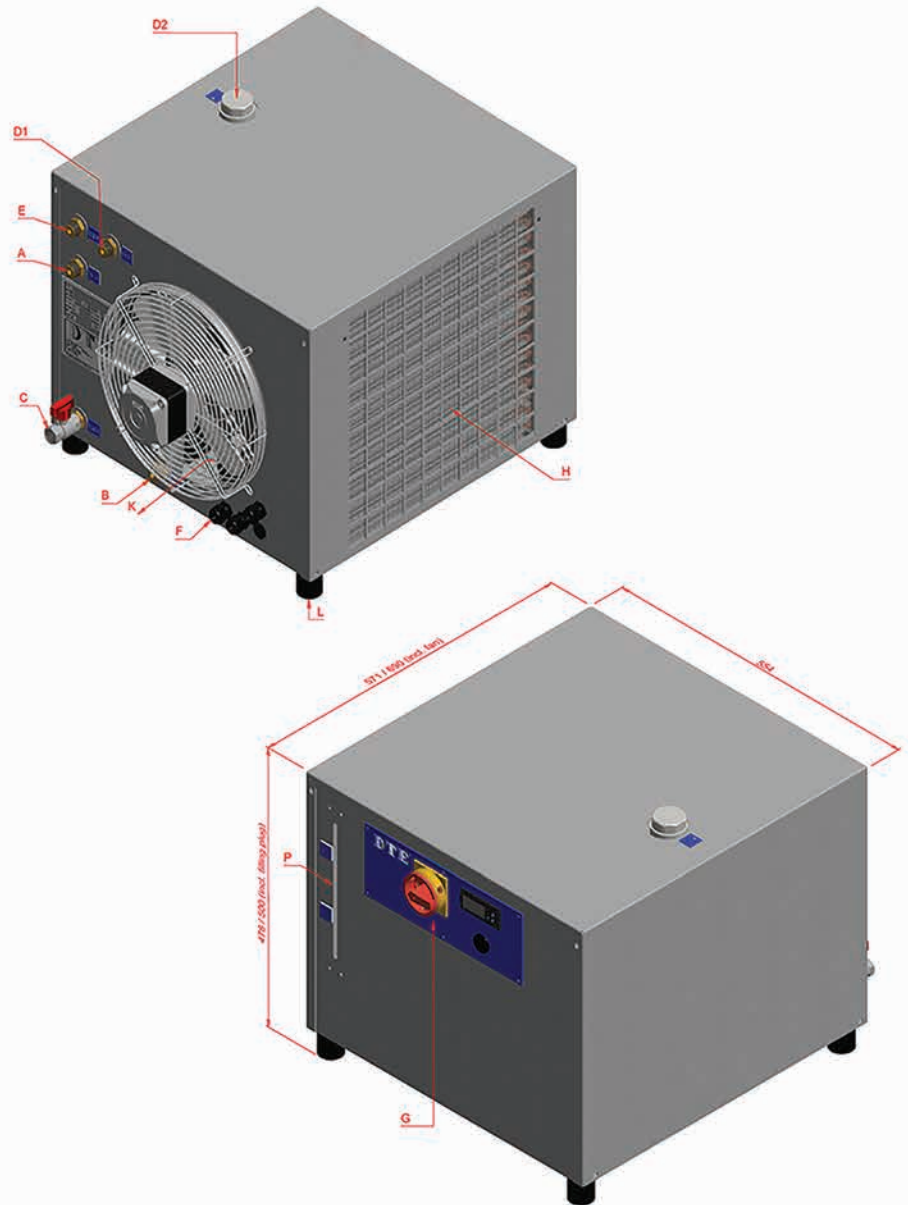

A = Cooling water inlet, 1/2" BSP outside thread
 B = Cooling water outlet, 1/2" BSP outside thread
 C = Drain, 1/2" BSP inside thread
 D₁ = Filling water connection, 1/2" BSP outside thread
 D₂ = Manual filling device
 E = Overflow water tank, 1/2" BSP outside thread

F = Electrical connection, PG-13,5
 G = Control panel
 H = Incoming condenser air
 K = Outgoing condenser air
 L = Rubber support legs
 P = Water level indicator

S1 series

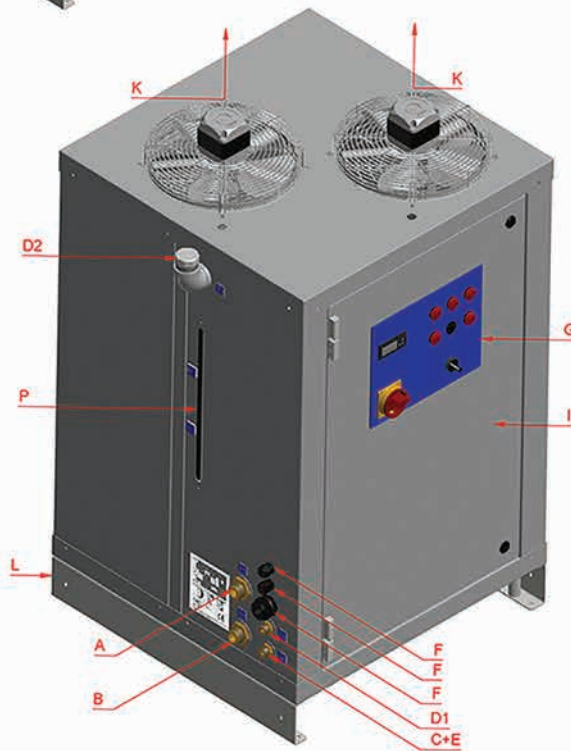
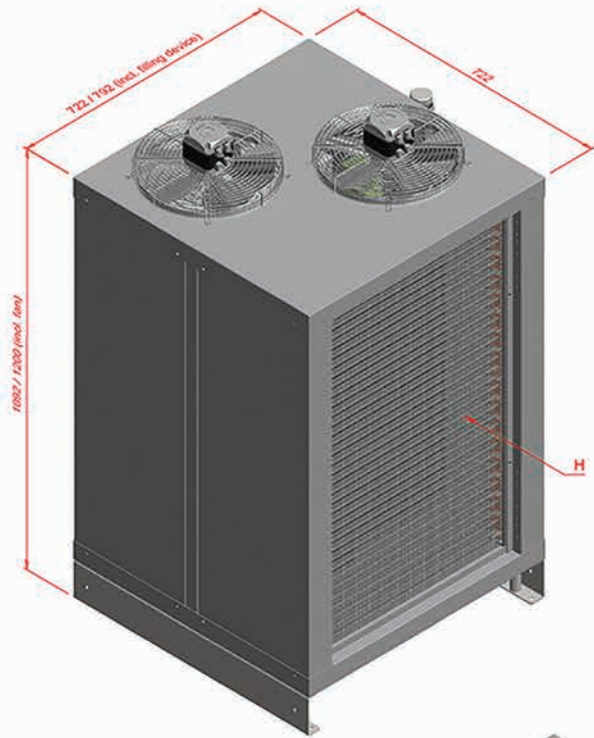

A = Cooling water inlet, 1" BSP outside thread
 B = Cooling water outlet, 1" BSP outside thread
 C = Drain, 1/2" BSP inside thread
 D1 = Filling water connection, 1/2" BSP outside thread
 D2 = Manual filling device
 E = Overflow water tank, 1/2" BSP outside thread
 F = Electrical connection, PG-16

G = Control panel
 H = Incoming condenser air
 I = Control box door
 K = Outgoing condenser air
 L = Stainless steel foot mounts, 2 pie
 P = Water level indicator

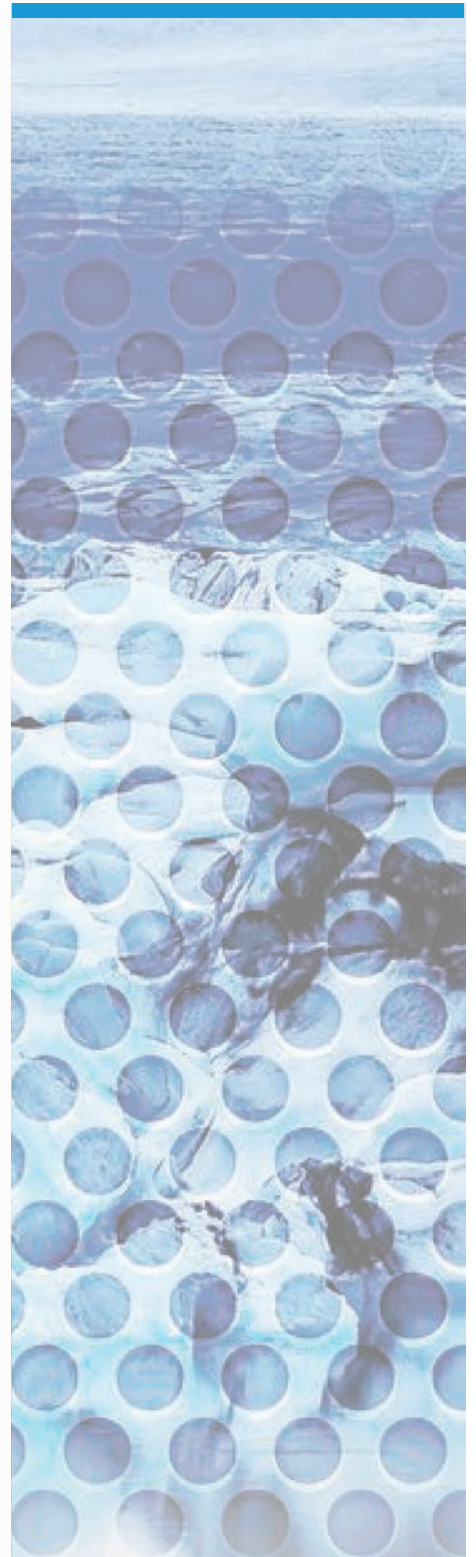

S2 series

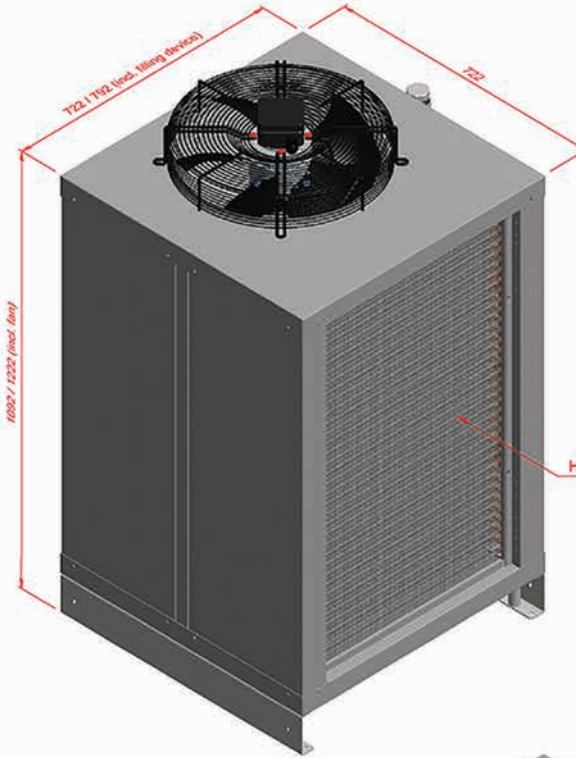
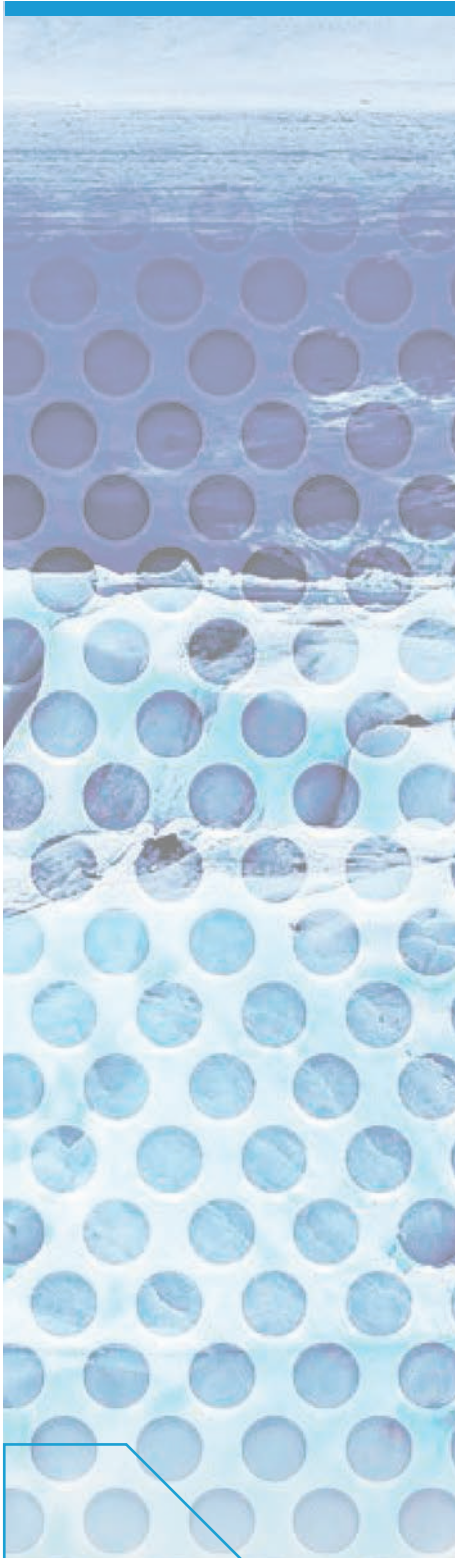

- | | |
|--|--|
| A = Cooling water inlet, 1" BSP outside thread | G = Control panel |
| B = Cooling water outlet, 1" BSP outside thread | H = Incoming condenser air |
| C = Drain, 1/2" BSP inside thread | I = Control box door |
| D ₁ = Filling water connection, 1/2" BSP outside thread | K = Outgoing condenser air |
| D ₂ = Manual filling device | L = Stainless steel foot mounts, 2 piece |
| E = Overflow water tank, 1/2" BSP outside thread | P = Water level indicator |
| F = Electrical connection, PG-16 | |

M1 series

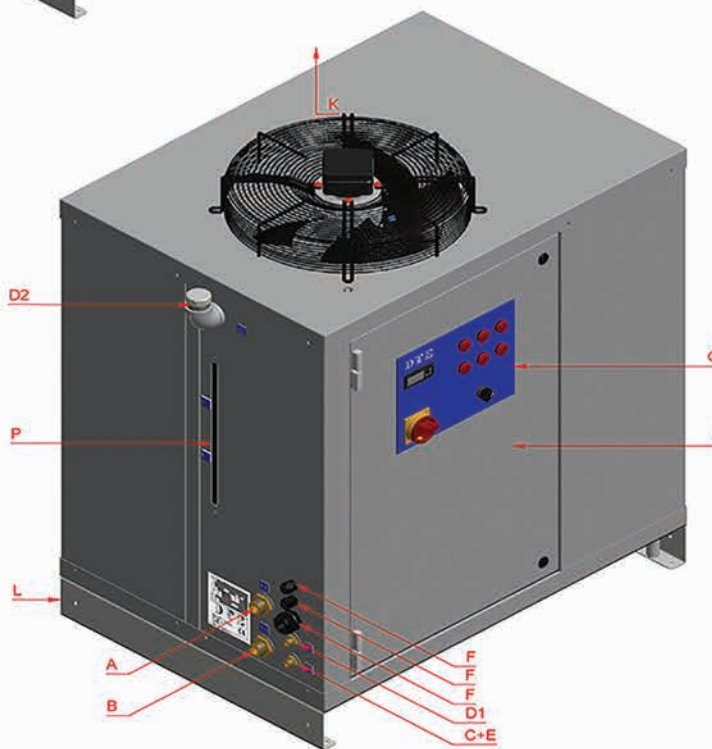
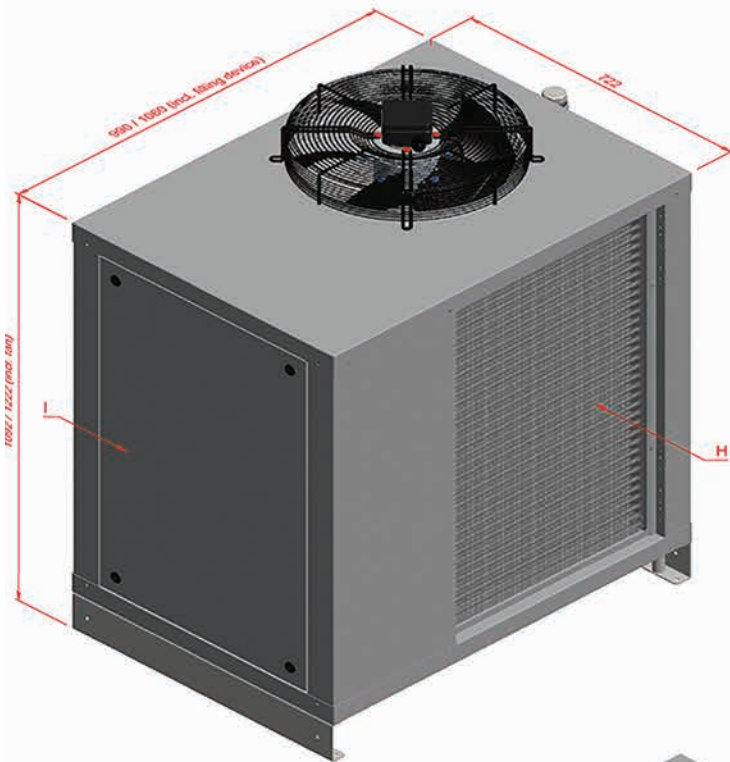

A = Cooling water inlet, 1" BSP outside thread
 B = Cooling water outlet, 1" BSP outside thread
 C = Drain, 1/2" BSP inside thread
 D₁ = Filling water inlet, 1/2" BSP outside thread
 D₂ = Manual filling device
 E = Overflow water tank, 1/2" BSP outside thread
 F = Electrical connection, PG-21

G = Control panel
 H = Incoming condenser air
 I = Control box door
 K = Outgoing condenser air
 L = Stainless steel foot mounts, 2 pie
 P = Water level indicator

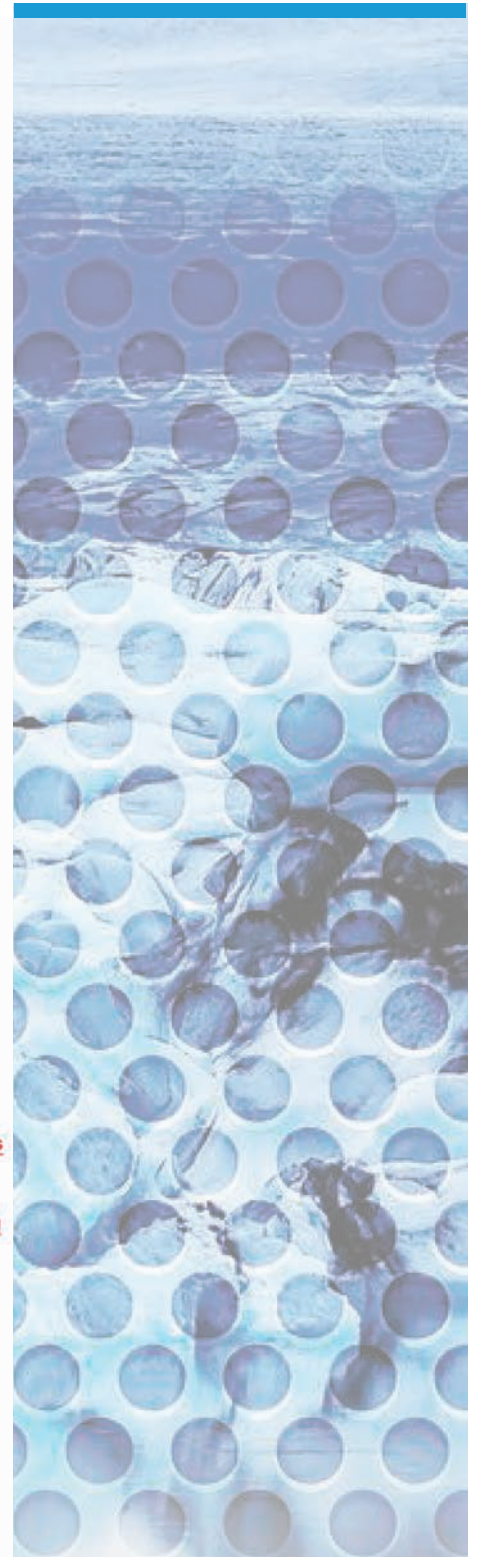

L1 series

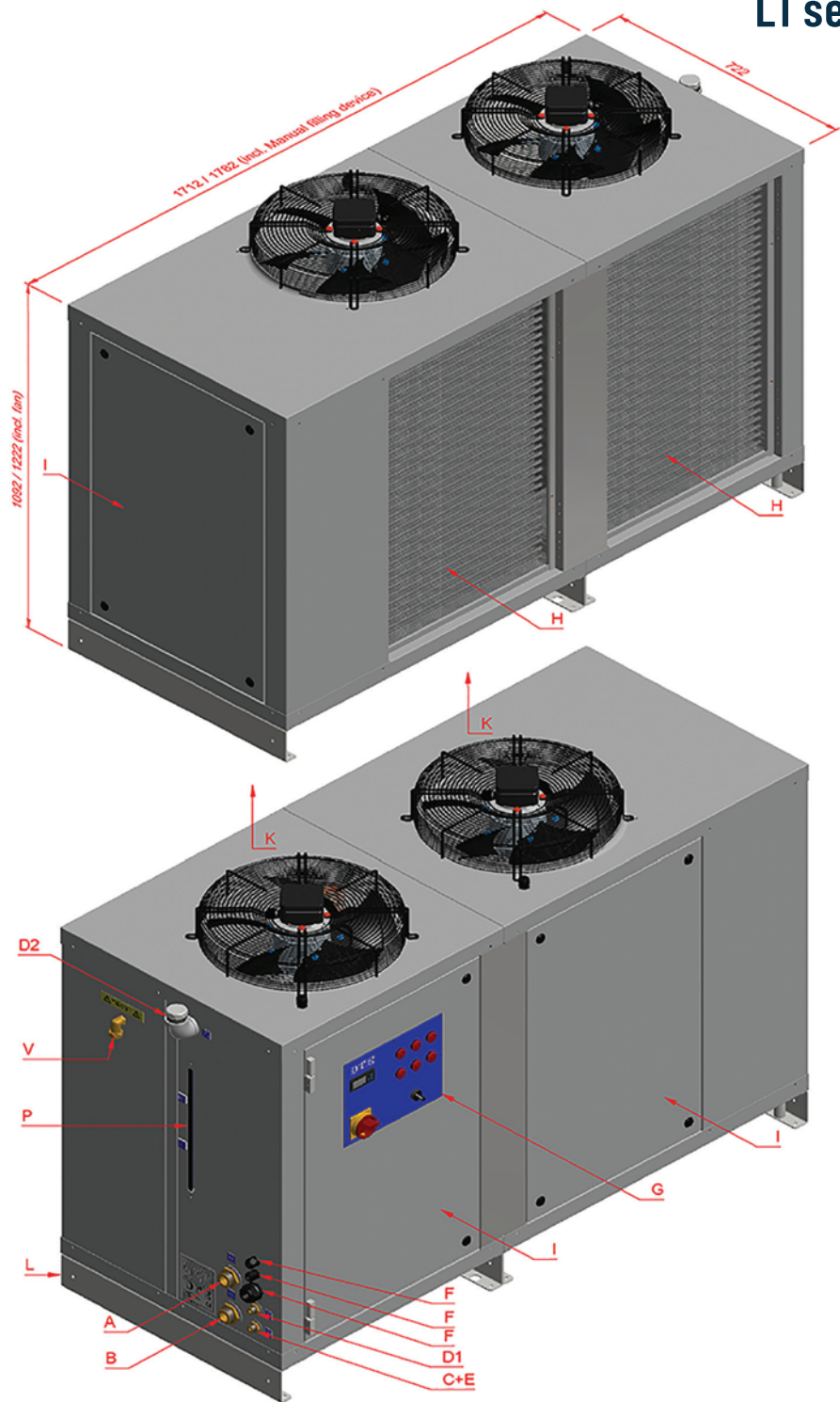
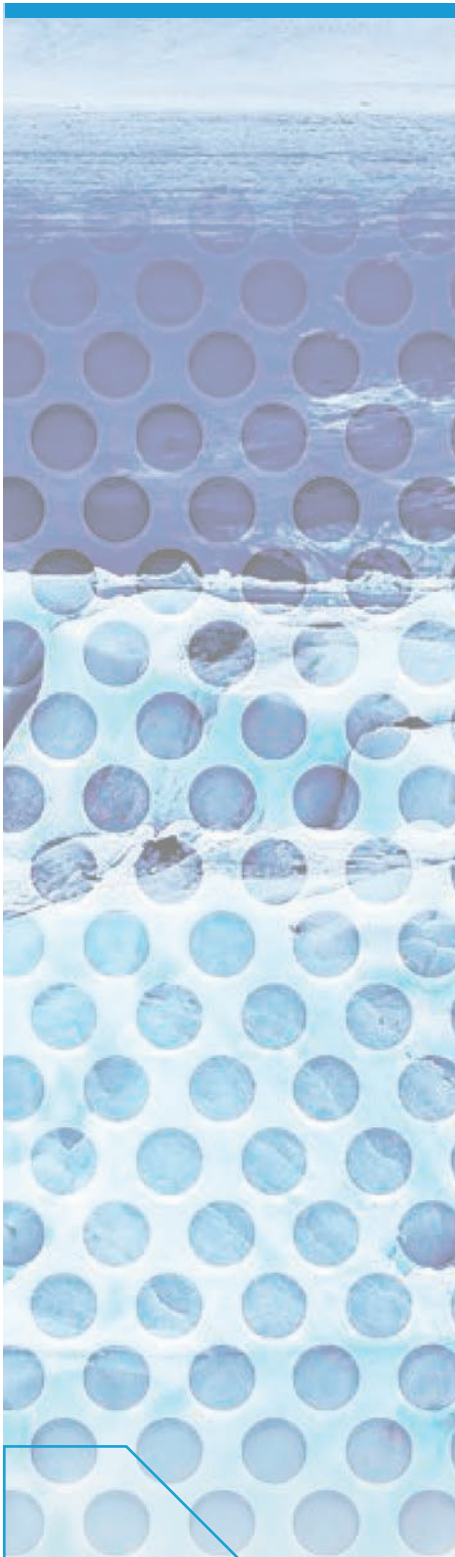

- A = Cooling water inlet, 1 1/4" BSP outside thread
- B = Cooling water outlet, 1 1/4" BSP outside thread
- C = Drain, 1/2" BSP inside thread
- D₁ = Filling water inlet, 1/2" BSP outside thread
- D₂ = Manual filling device
- E = Overflow water tank, 1/2" BSP outside thread
- F = Electrical connection, PG-29

- G = Control panel
- H = Incoming condenser air
- I = Control box door
- K = Outgoing condenser air
- L = Stainless steel foot mounts, 2 pieces
- P = Water level indicator
- V = Refrigerant relief

X1 series

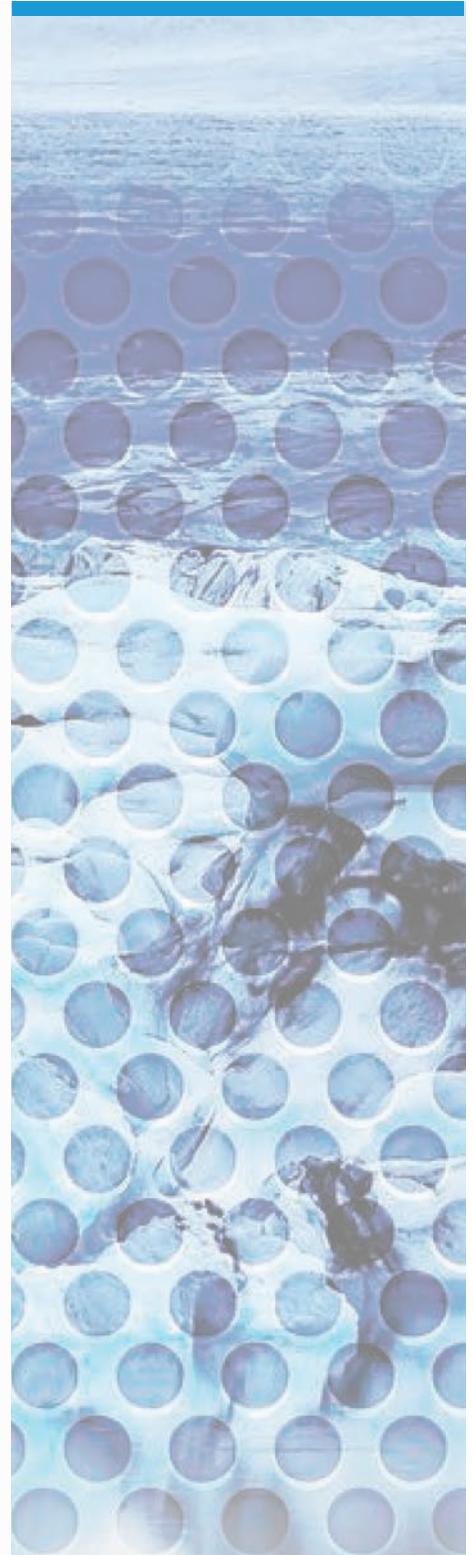
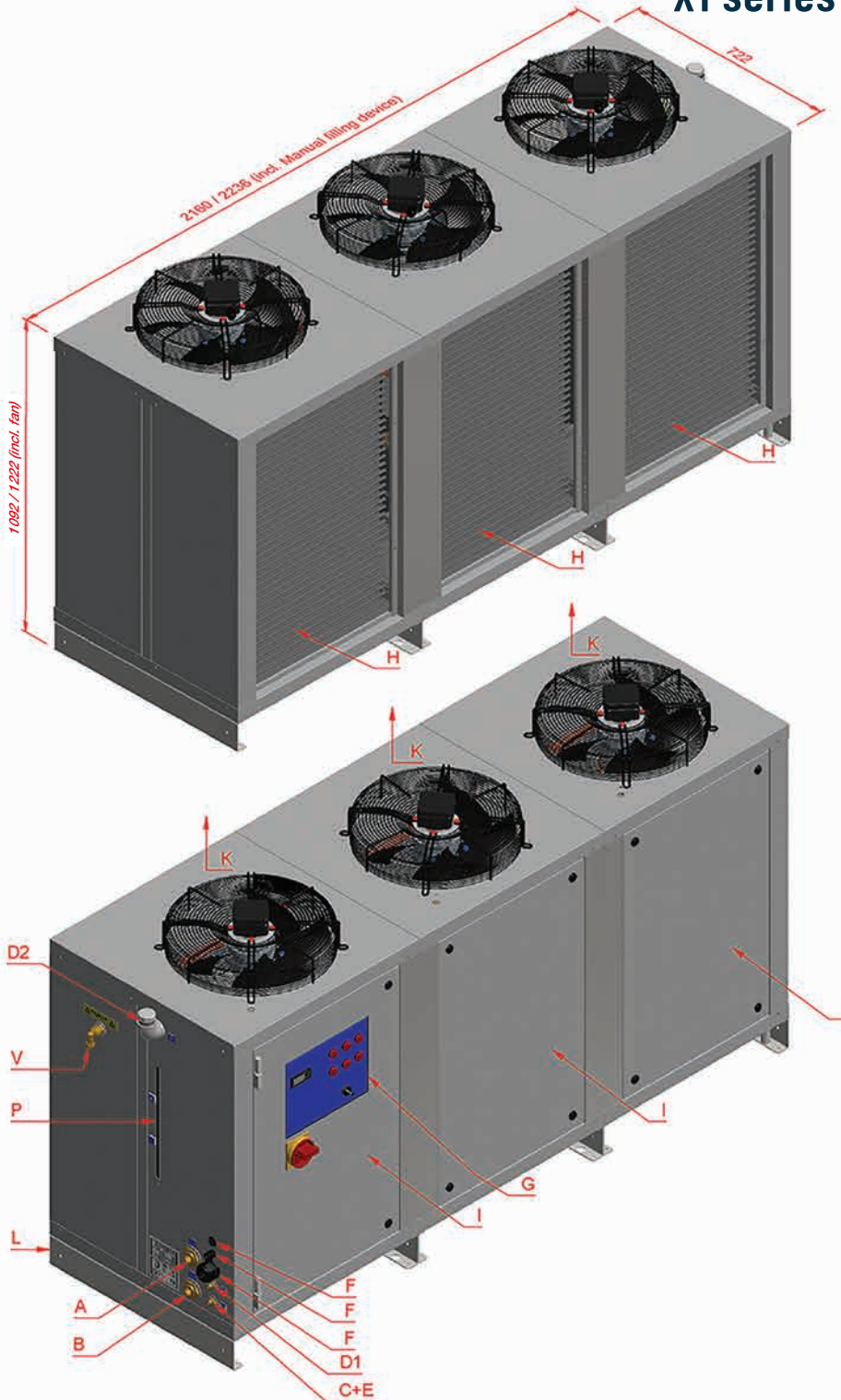

- A = Cooling water inlet, 1/4" BSP outside thread
- B = Cooling water outlet, 1/4" BSP outside thread
- C = Drain, 1/2" BSP inside thread
- D₁ = Filling water inlet, 1/2" BSP outside thread
- D₂ = Manual filling device
- E = Overflow water tank, 1/2" BSP outside thread
- F = Electrical connection, PG-29

- G = Control panel
- H = Incoming condenser air
- I = Control box door
- K = Outgoing condenser air
- L = Stainless steel foot mounts, 2 pi
- P = Water level indicator
- V = Refrigerant relief

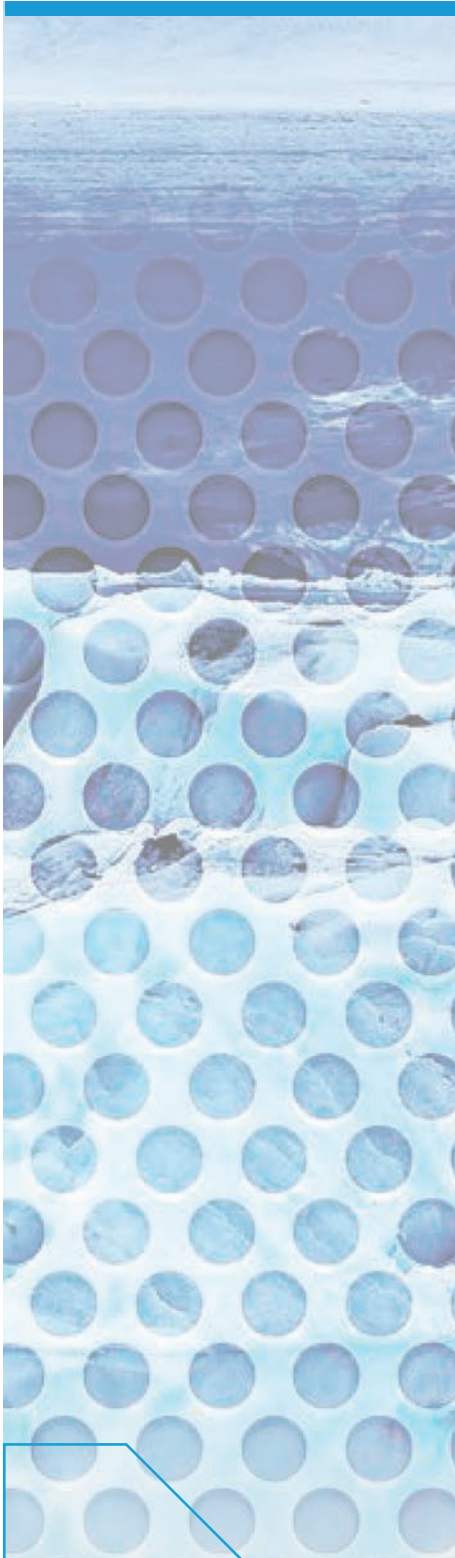

Pump curve K2 & S1

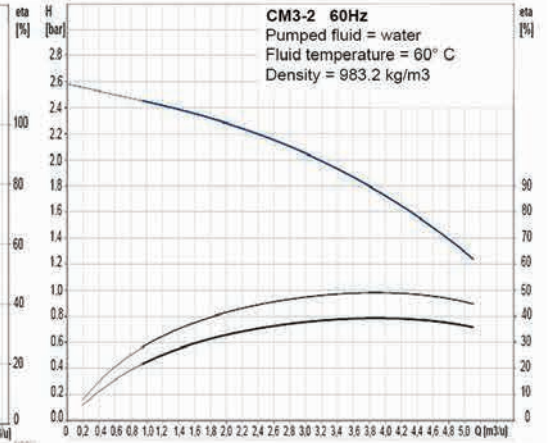
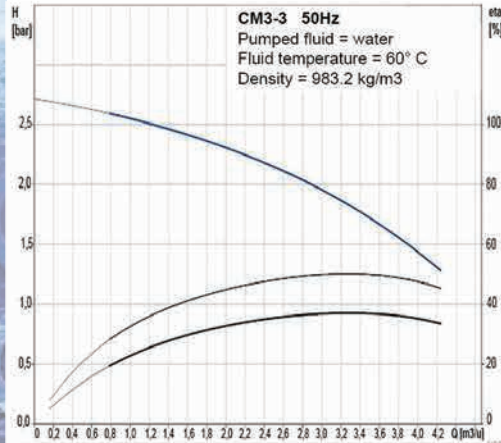

Pump curve S2, M1, L1 & X1 < 44kW

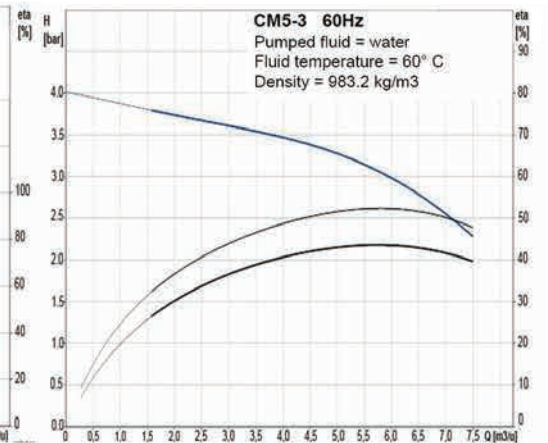
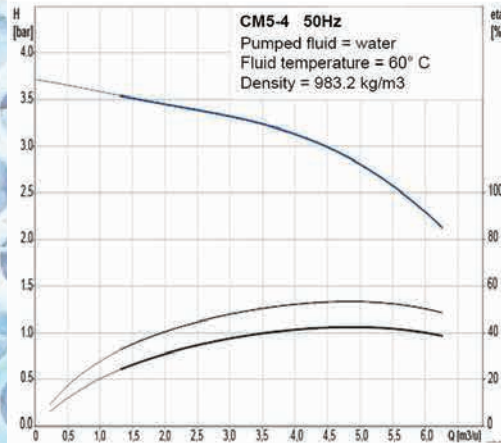

Pump curve X1 > 44kW

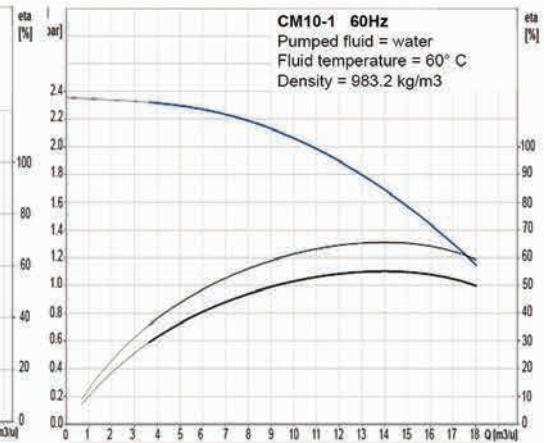
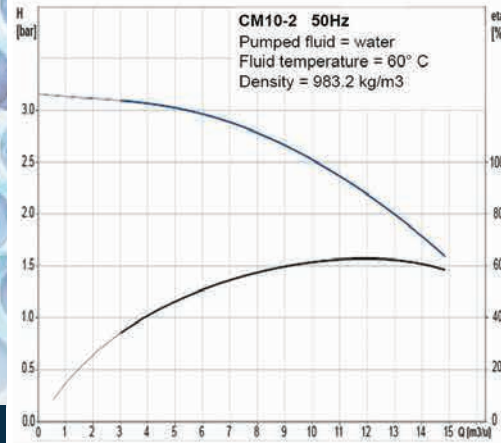

DTE is always at your service

The standard watercoolers mentioned in this brochure only represent a part of what DTE can do for you.

Our mission is to be enthusiastic and committed and always ready to support our clients. We are a proactive partner who wants to find the best solution regarding your cooling and heating needs.

Our commitment does not stop at the delivery and installation of our product. We ensure a systematic follow-up allowing continuous monitoring for proper operation of the installations. In our experience, this has led to satisfied clients and contented staff.

Our company philosophy is to enthuse everyone into being innovative and thinking about continuous improvement. When developing installations we work with a clear notion on sustainability and energy savings. This also has a positive effect on being more economical for the end user and also making a positive contribution to our environment.

With DTE as your partner for all your cooling, heating and tempering solutions, you can rely on the following:

- We know your challenges, designs, problems and installations
- DTE always provides realistic, tailor made solutions
- We offer short delivery times on our machines
- An extremely flexible organization and staff
- Installation at your location
- Worldwide 24/7 service
- Training for your staff
- Superior quality and reliability
- Excellent price/quality ratio
- Try us....and you will find a Partner for life!



DTE solutions for all your industrial temperature processes

Except our standard water coolers which are available with several options, DTE produces also all different kind of machines suitable for cooling and heating or tempering of your product. We have a very qualified team of engineers and technicians who convert every customer specification into a perfect solution for your process.

If you need an installation for cooling or heating or which can do both, a tempering installation or an installation which has to meet special regulations like ATEX Zone 1 & 2, UL/CSA or others, DTE is your partner for this job.

With over 30 years of experience in all sorts of salesmarkets, we have the know-how on all the different industrial processes and the challenges this can bring. Our engineers will think along with you to change a difficulty into a solution. Good cooperation between our engineers and technicians ensures that theory and practice are tuned and lead to perfect working assets for your industrial process.

From cooling for the production of candy or other foodproducts, oil-cooling or heating for telecommunicationsystems, controlsystems for industrial processes until cooling and heating for offshore, DTE can design and produce the installation that meets all your requirements. So if you need a perfect solution for your cooling, heating or tempering process, contact us!



Condenser unit

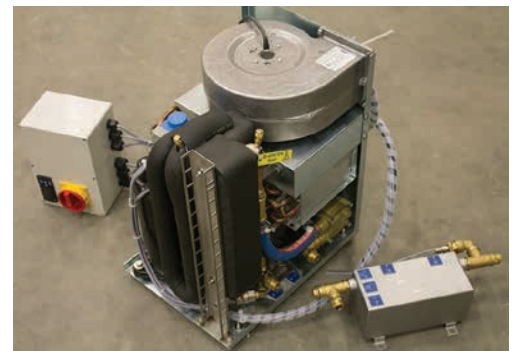

Oil cooling system

... always Dominating



DTE CombiMaster suitable with external condenser

DTE ControlMaster foodgrade

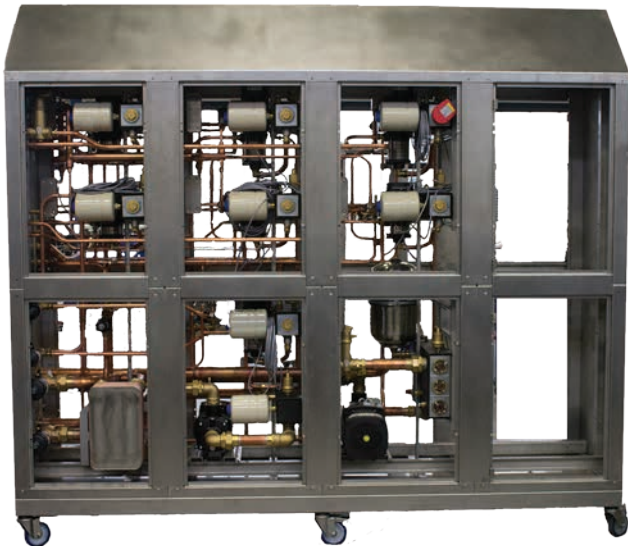

DTE Condenser

Through Excellence!

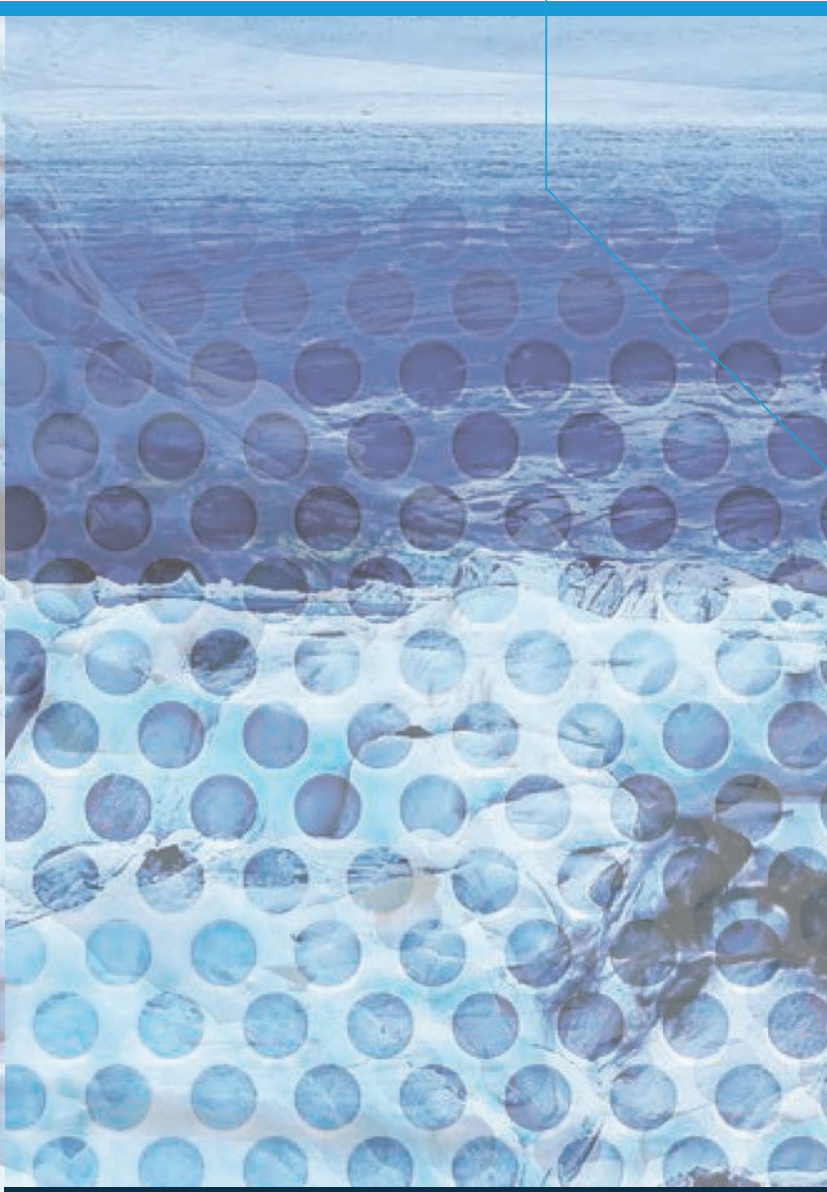

Dutch Thermal Engineering N.V.

Westerbroekstraat 18
7011 EX Gaanderen
The Netherlands

T +31 (0)315 - 32 83 11

E info@dte.eu